

Hoshizaki America, Inc.

Ice Dispensing Bin

Model
DB-130H



“A Superior Degree
of Reliability”

www.hoshizaki.com

SERVICE MANUAL



Number: 73128
Issued: 7-13-2005
Revised: 7-29-2005

IMPORTANT

Only qualified service technicians should attempt to service or maintain this dispensing bin. No service or maintenance should be undertaken until the technician has thoroughly read this Service Manual.

HOSHIZAKI provides this manual primarily to assist qualified service technicians in the service and maintenance of the dispensing bin.

Should the reader have any questions or concerns which have not been satisfactorily addressed, please call or write to the HOSHIZAKI Technical Support Department for assistance.

HOSHIZAKI AMERICA, INC.
618 Highway 74 South
Peachtree City, GA 30269

Attn: HOSHIZAKI Technical Support Department

Phone: 1-800-233-1940 Technical Service
(770) 487-2331
Fax: 1-800-843-1056
(770) 487-3360

Web Site: www.hoshizakiamerica.com

Note: To expedite assistance, all correspondence/communication **MUST** include the following information:

- Model Number
- Serial Number
- Complete and detailed explanation of the problem

Please review this manual. It should be read carefully before the dispensing bin is serviced or maintenance operations are performed. Only qualified service technicians should service and maintain the dispensing bin. This manual should be made available to the technician prior to service or maintenance.

CONTENTS

I. Specification	4
II. General Information	5
A. Construction.....	5
III. Technical Information	6
A. Wiring Diagram	6
IV. Service Diagnosis	7
V. Removal and Replacement of Components	9
A. Gear Motor and Chain	9
B. Safety Switch	9
C. Spout Switch	10
D. Solenoid	10
VI. Cleaning and Maintenance Instructions	11
A. Preparing the Ice Dispensing Bin for Long Storage	11
B. Cleaning Instructions.....	11
1. Cleaning Procedure.....	11
2. Sanitizing Procedure – Following Cleaning Procedure.....	13
C. Maintenance	13

I. Specification

AC SUPPLY VOLTAGE	115/60/1
AMPERAGE	1.4 A
MINIMUM CIRCUIT AMPACITY	15 A
MAXIMUM FUSE SIZE	15 A
APPROXIMATE ELECTRIC CONSUMPTION	110 W

APPROXIMATE STORAGE CAPACITY 130 lbs (60 Kg)

APPROXIMATE ICE DISPENSING SPEED 20 lbs/min (9 kg/min)

EXTERIOR DIMENSIONS (W x D x H)	22" x 30" x 53" (560 x 757 x 1346 mm) With 6" Legs
INTERIOR DIMENSIONS (W x D x H)	15.3" x 22.4" x 22.5" (389 x 569.5 x 571 mm)
EXTERIOR FINISH	Plastic/SUS Front Cover, P.V.C Galvanized Steel Side Panels Galvanized Steel Rear Panel
INTERIOR FINISH	Polyethelene 1 pc. Mold
INSULATION	Polyurethane Foam
WEIGHT	Net 178.4 lbs (81 kg), Shipping 220 lbs (100 kg)
CONNECTIONS - ELECTRIC	Permanent Connection
- DRAIN	Outlet 3/4" FPT
- WATER INLET	N/A

GEAR MOTOR	60 W
AGITATOR	Stainless Steel Round Bar 14.5" Dia.

GEAR MOTOR PROTECTION	Thermal Protector (Internal)
SAFTEY PROTECTION	Interlock Switch for Front Panel Saftey Switch for Ice Spout

ACCESSORIES - OPTIONAL 6" Legs, 4 pcs

OPERATING CONDITIONS	VOLTAGE RANGE	104 - 132 V
	AMBIENT TEMP.	45 - 100° F

We reserve the right to make changes in specifications and design without prior notice.

II. General Information

A. Construction

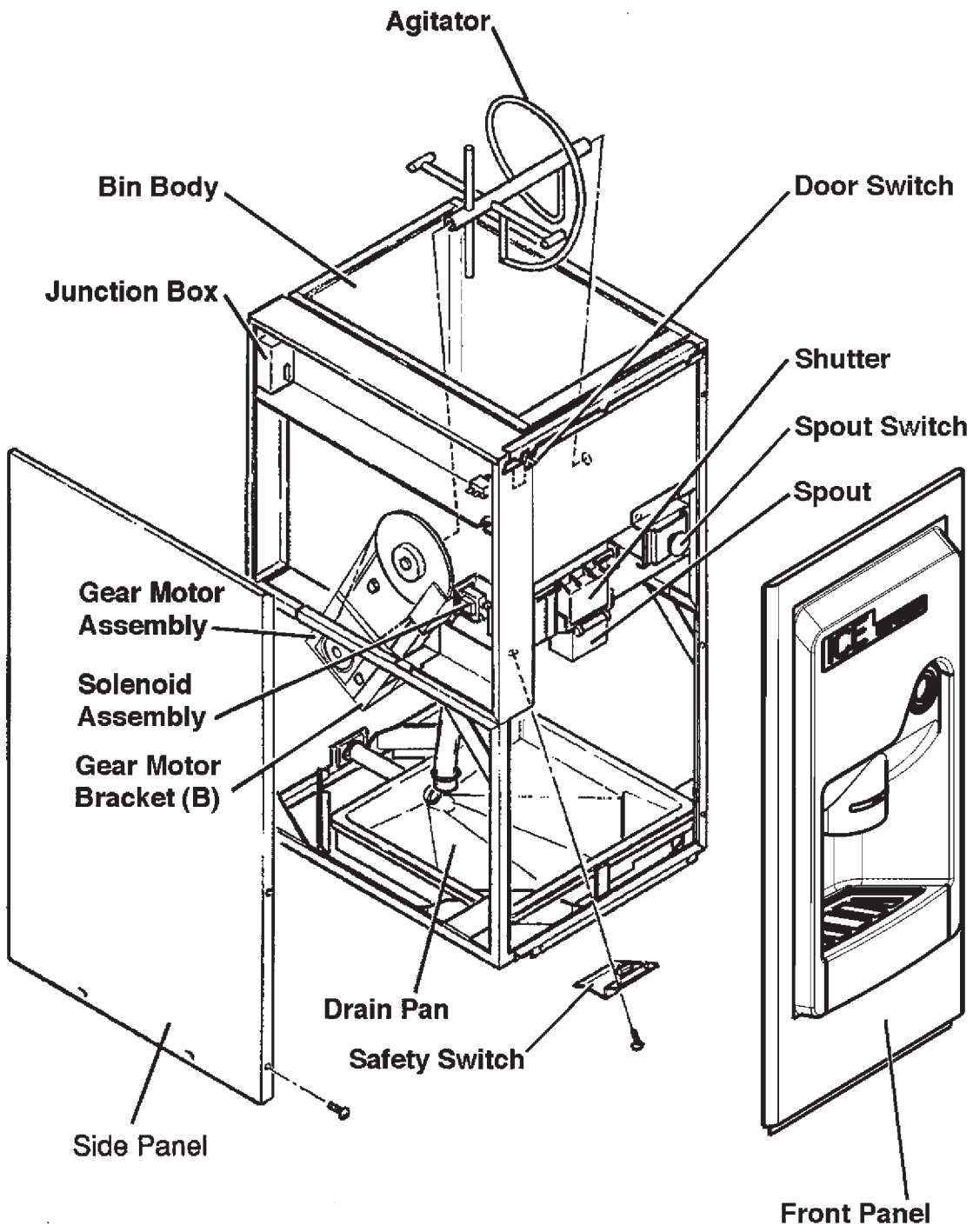

III. Technical Information

A. Wiring Diagram

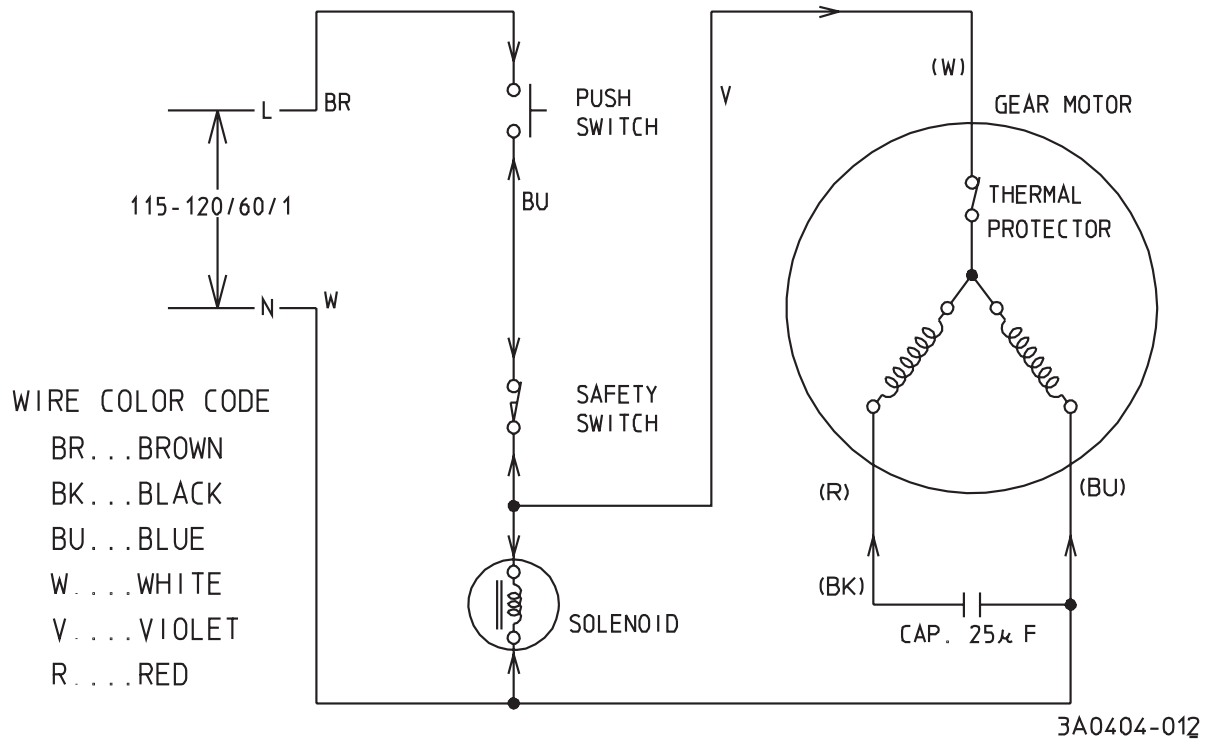

IV. Service Diagnosis

Problem	Possible Cause	Remedy	
[1] No ice dispensed.	a) Power Supply	1. "OFF" position.	1. Move to "ON" position.
		2. Loose connection.	2. Tighten.
		3. Bad contacts.	3. Check for continuity and replace.
		4. Voltage too high.	4. Check and get recommended voltage.
	b) Fuse (Inside Fused Disconnect, if any)	1. Blown.	1. Check for short circuit and replace.
	c) Spout Switch	1. Bad contacts.	1. Check for continuity and replace.
		2. Loose connection.	2. Tighten.
	d) Door Switch	1. Front panel is not in position.	1. Place in position.
		2. Actuating plate does not push door switch.	2. Check for continuity and adjust.
		3. Bad contacts.	3. Check for continuity and replace.
		4. Loose connection.	4. Tighten.
	e) Safety Switch	1. Spout is not in position.	1. Check for continuity and place in position.
		2. Bad contacts.	2. Check for continuity and replace.
		3. Loose connection.	3. Tighten.
	f) Gear Motor	1. Thermal protector is tripped.	1. Allow to cool.
		2. Gear motor winding opened.	2. Replace.
		3. Bearing worn out.	3. Replace.
		4. Wiring to gear motor.	4. Check for loose connection or open circuit, and replace wiring as needed.
		5. Defective capacitor.	5. Replace.
		6. Agitator rotates in reverse direction.	6. Check leads and reverse the connections.
	g) Solenoid	1. Solenoid winding open.	1. Replace
2. Wiring to solenoid.		2. Check for loose connection or open circuit, and replace wiring as needed.	
3. Overload due to loosening screws.		3. After tightening, apply thread sealant to the parts.	

Problem	Possible Cause		Remedy
	h) Mechanism	1. Chain out of position or loose.	1. Place in position or tighten.
		2. Corrosion.	2. Apply oil.
		3. Key of sprocket is not in position.	3. Place in position.
		4. Bad alignment of sprocket.	4. Readjust.
		5. Foreign matter interrupting agitator.	5. Remove foreign matter.
	i) Ice Storage	1. No ice or little ice in storage bin.	1. Make ice.
		2. Ice bridge or block formed.	2. Break with a poker.
[2] Abnormal noise.	a) Gear Motor or Gear Head	1. Bearing worn out.	1. Replace.
		2. Grease leaks.	2. Supply grease and replace O-ring.
	b) Mechanism	1. Bad setting.	1. Apply oil and readjust.
		2. Bad alignment of sprocket.	2. Readjust.
		3. Foreign matter interrupting agitator.	3. Remove foreign matter.
	c) Solenoid	1. Overload due to loosening screws.	1. After tightening, apply thread sealant to the parts.
2. Foreign matter on plunger.		2. Clean.	
[3] Ice in storage bin often melts.	a) Bin Drain	1. Foreign matter blocking bin drain.	1. Remove foreign matter.

V. Removal and Replacement of Components

A. Gear Motor and Chain

- 1) Turn off the power supply.
- 2) Remove the front panel and left side panel.
- 3) Loosen the four bolts holding Gear Motor Bracket (B) and the adjusting bolt.
- 4) Remove the chain.
- 5) Loosen the socket set screw and remove the sprocket by using a gear puller.
- 6) Install a new gear motor.
NOTE: When removing the gear motor and gear head, take care to keep the grease.
- 7) Assemble the removed parts in the reverse order of the above procedure.
NOTE:
 - When weight (2.2 lb) is applied to the chain at the center, the displacement must be 0.31 to 0.51".
 - Lubricant (Class SAE 20) must be applied to the chain using a cloth.
- 8) Turn on the power supply.

B. Safety Switch

- 1) Turn off the power supply.
- 2) Remove the front panel.
- 3) Remove the safety switch cover.
- 4) Disconnect the connectors from the safety switch leads.
- 5) Install a new safety switch.
- 6) Assemble the removed parts in the reverse order of the above procedure.
- 7) Turn on the power supply.

C. Spout Switch

- 1) Turn off the power supply.
- 2) Remove the front panel.
- 3) Remove the spout switch assembly and Barrier (A).
- 4) Disconnect the connectors from the spout switch leads.
- 5) Install a new spout switch.
- 6) Assemble the removed parts in the reverse order of the above procedure.
- 7) Turn on the power supply.

D. Solenoid

- 1) Turn off the power supply.
- 2) Remove the front panel and the left side panel.
- 3) Disconnect the connectors from the solenoid leads, and remove the solenoid assembly.
- 4) Remove the solenoid, and install a new solenoid. Securing torque should be 13 to 17.3 in. lb.
- 5) Assemble the removed parts in the reverse order of the above procedure.
- 6) Turn on the power supply.

VI. Cleaning and Maintenance Instructions

IMPORTANT

Ensure all components, fasteners and thumbscrews are securely in place after any maintenance or cleaning is done to the equipment.

A. Preparing the Ice Dispensing Bin for Long Storage

IMPORTANT

Drain the icemaker and remove all ice from the ice dispensing bin when shutting off the icemaker/ice dispensing bin for storage. The ice dispensing bin should be cleaned and wiped dry.

- 1) Shut off the icemaker. See the "Preparing the Icemaker for Long Storage" instructions on the icemaker.
- 2) Turn off the power supply switches for both the icemaker and the ice dispensing bin after removing all ice.
- 3) Clean the ice dispensing bin and wipe it dry.

B. Cleaning Instructions

WARNING

1. HOSHIZAKI recommends cleaning this unit at least once a year. (See the "Cleaning Instructions" on the icemaker.) More frequent cleaning, however, may be required in some existing water conditions.
2. To prevent injury to individuals and damage to the icemaker/ice dispensing bin, do not use ammonia type cleaners.
3. Always wear liquid-proof gloves to prevent the cleaning and sanitizing solutions from coming into contact with skin.

1. Cleaning Procedure

- 1) Clean and sanitize the ice dispensing bin/icemaker (see the cleaning instructions on the icemaker) as conditions require.
- 2) Remove all ice from the bin.
- 3) Disconnect electrical power to the ice dispensing bin/icemaker.
- 4) Remove the drain gate and simply lift out the chute for cleaning.
- 5) Remove or reposition the icemaker to allow access to the inside. Be sure that the icemaker is secured and cannot fall.

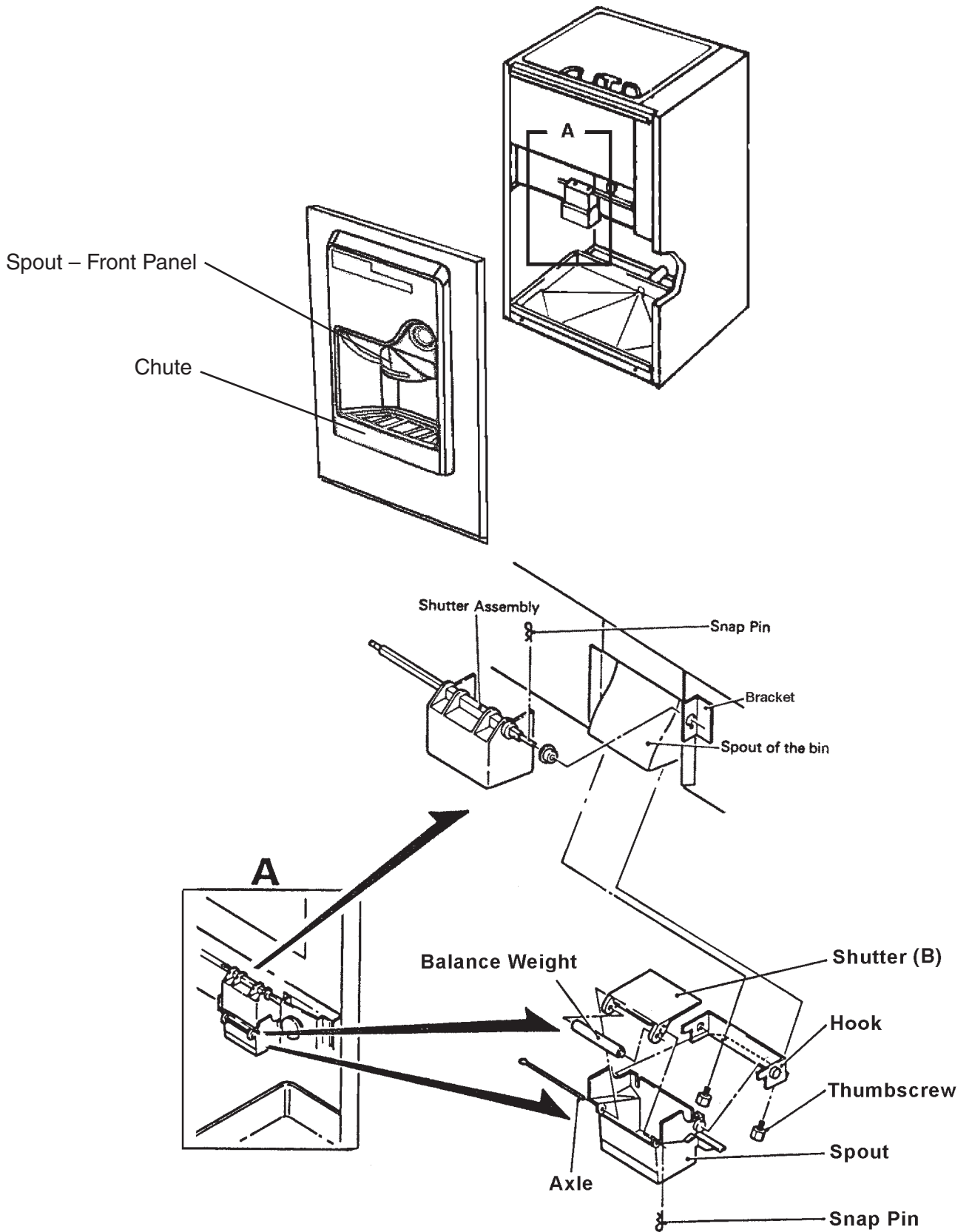

- 6) Scrub the inside of the bin, the agitator, the spout of the bin, the spout of the front panel and chute using a nylon scouring pad, brushes and cleaning solution, such as 5 oz. Hoshizaki "Scale Away" in one gallon of water.
- 7) Remove the shutter assembly and spout and scrub them using the cleaning solution made in step 6. See the illustration on the previous page.
 - a) Remove the snap pin fitted to the shutter shaft and shift the shaft to the right. Then the shutter assembly can be removed from the bin.
 - b) Pull out on the sides of the hook to release the spout. Lift the spout up and out from the bin.
 - c) Remove the thumbscrews holding the hook and take it off the spout. Take off the snap pin and the axle from Shutter (B). Open out Shutter (B) and remove the balance weight.
- 8) Rinse all parts thoroughly with clean water.

2. Sanitizing Procedure – Following Cleaning Procedure

- 1) Wash all parts in steps 6) and 7) using the following sanitizing solution: 1/2 fl. oz. of a 5.25% sodium hypochlorite solution (chlorine bleach) diluted in 1 gallon of water.
- 2) Rinse all parts thoroughly with clean water.
- 3) Reassemble in the reverse order of the removal procedure.
- 4) Turn on the icemaker/ice dispensing bin.
- 5) Check for proper operation.

C. Maintenance

- 1) Exterior Panels
To prevent corrosion, wipe occasionally with a clean, soft cloth. Use a damp cloth containing a neutral cleaner to wipe off oil or dirt build up.
- 2) In view of the simple design of this ice dispensing bin, and the limited operating time, very little maintenance is required.
Inspect and oil the chain (2 or 3 drops) annually. Adjust as necessary for 3/8" to 1/2" free play.