



Outperform every day.™

ENGLISH

Operator's Manual



Grill Tender™ 1101



Thank you for purchasing this Vollrath Food Processing Equipment. Before operating the equipment, read and familiarize yourself with the following operating and safety instructions. **SAVE THESE INSTRUCTIONS FOR FUTURE REFERENCE.** Save the original box and packaging. Use this packaging to ship the equipment if repairs are needed.

SAFETY PRECAUTIONS

To ensure safe operation, read the following statements and understand their meaning. This manual contains safety precautions which are explained below. Please read carefully.

WARNING

Warning is used to indicate the presence of a hazard that can cause severe personal injury, death, or substantial property damage if the warning is ignored.

CAUTION

Caution is used to indicate the presence of a hazard that will or can cause minor personal injury or property damage if the caution is ignored.

NOTE

Note is used to notify people of installation, operation, or maintenance information that is important but not hazard-related.

For Your Safety!

These precautions should be followed at all times. Failure to follow these precautions could result in injury to yourself and others or damage the equipment.

To reduce risk of injury or damage to the equipment:

- Check equipment before each use to insure the equipment is clean.
- Check for broken, nicked or dull blades and if found, replace the blade assembly.
- Check to insure that the pusher head sits down completely on the rubber bumpers.
- Always hold the handle and knob when using this equipment.
- Allow grill surface to cool prior to using this equipment.

FUNCTION AND PURPOSE

Intended for cleaning flat grill surfaces.

FEATURES AND CONTROLS

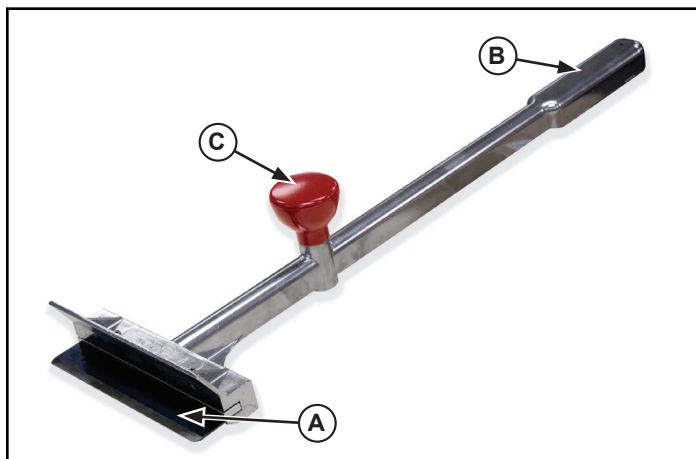

Figure 1. Features and Controls

- (A) BLADE. Scrapes the carbonized food and residue from flat grill surfaces.

- (B) HANDLE. Used to control the blade during operation.

- (C) KNOB. Used to control the blade during operation.

UNPACKING THE EQUIPMENT AND INITIAL SETUP

Carefully remove crating or packaging materials from the equipment. When no longer needed, dispose of all packaging materials in an environmentally responsible manner.

OPERATION

	WARNING
	Sharp Blade Hazard. Blades are sharp and can cause cuts. To avoid injury from sharp blades, handle with caution.

Prior to first use, it is important to clean the equipment. Wash new blades with warm soapy water and rinse thoroughly to remove the thin protective oil film.

1. Before each use, check that the equipment is clean and the blades are in good condition. If loose or broken blades are found, blades must be serviced.
2. With one hand on the handle (B) and other hand on the knob (C), place the Grill Tender® scraper on the grill surface. See Figure 1. With a firm front-to-back motion, scrap the carbonized food particles from the grill surface.
3. Repeat step 2 as needed.
4. Clean your equipment immediately after each use. See the **CLEANING** section of this manual for more information.

CLEANING

	WARNING
	Sharp Blade Hazard. Blades are sharp and can cause cuts. To avoid injury from sharp blades, handle with caution.

To maintain the appearance and increase the service life, clean your daily.

NOTE:

Food acids will make blades dull and corrode the metal. Always clean this food preparation equipment immediately after every use.

1. Wipe, rinse or spray off equipment, and blade (A) thoroughly with mild soap and HOT water.
2. Rinse and allow equipment to air dry.

REPLACING BLADE ASSEMBLY

	WARNING
	<p>Sharp Blade Hazard. Blades are sharp and can cause cuts. To avoid injury from sharp blades, handle with caution.</p>

Wash new blades with warm, soapy water and rinse thoroughly to remove the thin protective oil film. Keep the sharp edge away from you when handling blade.

1. Familiarize yourself with the **Exploded View** diagram for your equipment.
2. Loosen the set screws with an Allen wrench. See Figure 2.
3. Carefully remove the blade (A) and pressure plate (D). Properly dispose of the old blade.
4. Carefully align the replacement blade (A) and pressure plate (D) into the groove of the head section casting/handle (B).
5. With the pressure plate (B) and blade (A) in place, firmly tighten the set screws (E).

SPARE PARTS LIST

Call Out	Part No.	Description
A	1102R	Blade, Single G.T.S.
B	1105R	Knob Assembly includes Knob and Bolt
C	1106R	Blade Pressure Plate
D	1107R	Set Screws

EXPLODED VIEW

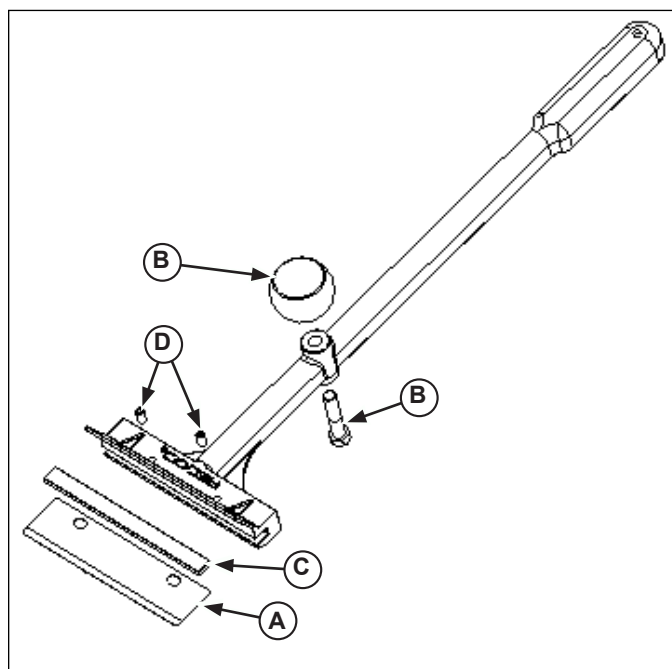

Figure 2. Exploded View

SERVICE AND REPAIR

Please contact the qualified professional repair service listed below.

VOLLRATH Technical Service • 1-800-628-0832
• Email: techservicereps@vollrathco.com

When contacting the Authorized Professional Service Center, please be ready with the item number, model number (if applicable), serial number, and proof of purchase showing the date the equipment was purchased.

WARRANTY STATEMENT FOR THE VOLLRATH Co. L.L.C.

This warranty does not apply to products purchased for personal, family or household use, and The Vollrath Company LLC does not offer a written warranty to purchasers for such uses.

The Vollrath Company LLC warrants each of its products listed below against defects in materials and workmanship for the applicable period provided below. All other products manufactured or distributed by The Vollrath Company LLC are warranted against defects in materials and workmanship for a period of one year. In all cases, the warranty runs from the date of the end user's original purchase found on the receipt.

- Vollrath – Redco® products – The warranty period is 2 years
- Replacement parts – The warranty period is 90 days.

For complete warranty information, product registration and new product announcement, visit www.vollrath.com.



www.vollrath.com

The Vollrath Company, L.L.C.
1236 North 18th Street
Sheboygan, WI 53081-3201
U.S.A.

Main Tel: 800.628.0830
Fax: 800.752.5620

Technical Services: 800.628.0832
Service Fax: 920.459.5462

Canada Service: 800.695.8560

© 2014 The Vollrath Company, L.L.C.