

Operator's Manual



Cheese Blocker[™] 1837



Thank you for purchasing this Vollrath Counter Top Cooking Equipment. Before operating the unit, read and familiarize yourself with the following operating and safety instructions. **SAVE THESE INSTRUCTIONS FOR FUTURE REFERENCE.** Save the original box and packaging. Use this packaging to ship the unit if repairs are needed.

SAFETY PRECAUTIONS

To ensure safe operation, read the following statements and understand their meaning. This manual contains safety precautions which are explained below. Please read carefully.

WARNING

Warning is used to indicate the presence of a hazard that *can* cause severe personal injury, death, or substantial property damage if the warning is ignored.

CAUTION

Caution is used to indicate the presence of a hazard that *will* or *can* cause *minor* personal injury or property damage if the caution is ignored.

NOTE

Note is used to notify people of installation, operation, or maintenance information that is important but not hazard-related.

For Your Safety!

These precautions should be followed at all times. Failure to follow these precautions could result in injury to yourself and others.

To reduce risk of injury or damage to the unit:

- Check unit before each use to insure the equipment is clean.
- Check for broken, blade/wire and if found, replace the blade/wire assembly.

FUNCTION AND PURPOSE

Intended for cutting cheese and other soft food products.

FEATURES AND CONTROLS

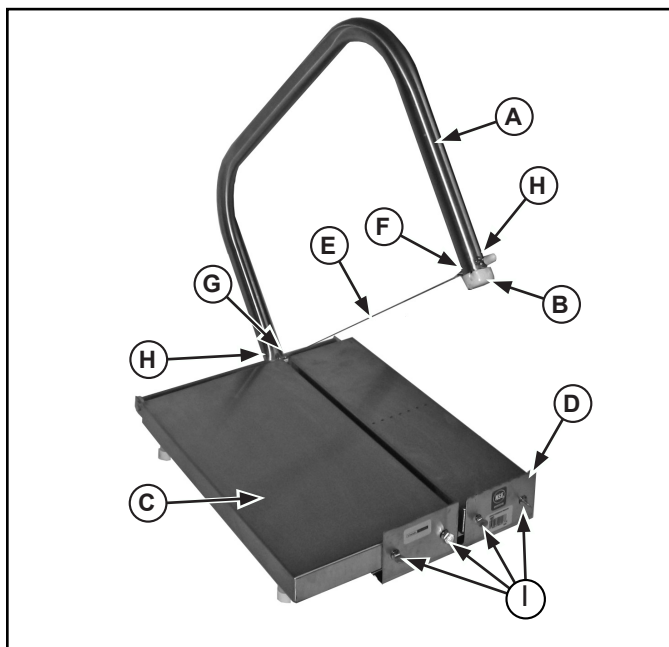

Figure 1. Features and Controls of the Cheese Blocker.

- (A) CUTTING BOW ASSEMBLY. Rotates on the pivot pin and holds the cutting wire.
- (B) HANDLE END CAP. Covers the end of the cutting bow.

- (C) BASE ASSEMBLY. Supports the food product.
- (D) FRONT PLATE. Supports the front edge of the food product.
- (E) CUTTING WIRE. Cuts through the food product.
- (F) EYE BOLT. Holds the front of the cutting wire.
- (G) "L" BOLT. Holds the back of the cutting wire.
- (H) WING NUT. Secures the bolts and cutting wire.
- (I) THUMB SCREWS. Secures the front plate to the base assembly.

UNPACKING THE EQUIPMENT AND INITIAL SETUP

Carefully remove packaging materials from the unit. When no longer needed, dispose of all packaging, materials in an environmentally responsible manner.

OPERATION

	WARNING
	Sharp Blade/Wire Hazard. Blade/Wires are sharp and can cause cuts. To avoid injury from sharp blades/wires, handle with caution.

Prior to first use, it is important to clean the unit. Wash new unit with warm soapy water and rinse thoroughly to remove the thin protective oil film.

1. Place the unit on a clean, flat work surface.
2. Before each use, check that the unit is clean and the cutting wire (E) is in good condition. If loose or broken, the cutting wire must be replaced. See Figure 1.
3. Prepare the food product to be processed.
4. Lift the cutting bow assembly (A) and place the food product on base assembly (C) and against the front plate (D).
5. Using a slow, consistent movement draw the cutting wire (E) through the food product.
6. Repeat this process until you have prepared enough food product for your daily needs.
7. Clean and lubricate your machine immediately after each use. See the **CLEANING** section of this manual for more information.

CLEANING

	WARNING
	Sharp Blade/Wire Hazard. Blades are sharp and can cause cuts. To avoid injury from sharp blades, handle with caution.

To maintain the appearance and increase the service life, clean your daily.

NOTE:

Food acids will make blades dull and corrode the metal. Always clean this food preparation machine immediately after every use.

1. Remove the thumb screws (I) and front plate (D) from the base assembly (C).





2. Wipe, rinse or spray off the base assembly (C), cutting bow assembly (A) and front plate (D) thoroughly with HOT water.
3. Do not put this machine in a dishwasher or dish machine with soaps, detergents, or other alkaline chemicals that can harm the machine.
4. After cleaning, let the machine air dry.
5. Install the front plate (D) and securing with the thumb screws (I).

PREVENTATIVE MAINTENANCE

1. Clean machine after every use.
2. Use for intended purposes only.
3. Change blade/wire regularly - based on usage.

REPLACING CUTTING WIRE ASSEMBLY

	 WARNING
<p>Sharp Blade/Wire Hazard. Blades are sharp and can cause cuts. To avoid injury from sharp blades, handle with caution.</p>	

Wash new cutting wire with warm, soapy water and rinse thoroughly to remove the thin protective oil film.

WARRANTY STATEMENT FOR THE VOLLRATH CO. L.L.C.

The Vollrath Company LLC warrants the products it manufactures and distributes against defects in materials and workmanship for a period of one year, except as specifically provided below. The warranty runs 12 months from the date of original installation. (End user receipt)

1. Refrigeration compressors – The warranty period is 5 years.
2. Replacement parts – The warranty period is 90 days.
3. Fry pans and coated cookware – The warranty period is 90 days
4. EverTite™ Riveting System – The warranty covers loose rivets only, forever.
5. Cayenne® Heat Strips – The warranty period is 1 year plus an additional 1 year period on heating element parts only.
6. Ultra and Professional Induction Ranges – The warranty period is 2 years.
7. Mirage and Commercial Induction ranges - The warranty period is 1 year.
8. ServeWell® Induction Workstations – The warranty period is one year on the workstation table and 2 years on induction hobs.
9. Slicers – The warranty period is 10 years on gears and 5 years on belts.
10. Mixers – The warranty period is 2 years.
11. Extended warranties are available at the time of sale.
12. Boxer Mixers – 1 Year exchange Warranty.
13. Vollrath – Redco products – The warranty period is 2 years.
14. Optio / Arkadia product lines – The warranty period is 90 days.
15. All non-stick products (i.e. fry pans and surfaces) are 90 days for the non stick surfaces.

All products in the Jacob's Pride® collection, including the following, have a lifetime warranty:

- NSF Certified One-Piece Dishes
- NSF Certified Spoodle® Utensils
- NSF Certified Heavy-Duty Spoons with Ergonomic Handle
- NSF Certified Heavy-Duty Basting Spoons
- Heavy duty Turners with Ergonomic handle
- One-Piece Tongs*
- Heavy-Duty One-Piece Ladles*
- Nylon Handle Whips
- One-Piece Skimmers
- Tribute®, Intrigue®, and Classic Select® Cookware*

*Jacob's Pride® warranty does not cover Kool-Touch®, non stick coatings and silicone handles.

Items sold having no warranty:

- Meat Grinder Knives
- Light Bulbs in Convection Ovens and Hot Food Merchandiser
- Oven Door Seals
- Oven Door Glass
- Hot Food Merchandisers / Display Case Glass
- Calibration and set up of gas equipment
- Slicer / Dicer blades (table top food prep) – Redco and Vollrath

1. Loosen the wing nuts (H) holding the eye bolt (F) and the "I" bolt (G). It is not necessary to remove the bolts or wing nuts to replace the cutting wire (E). See Figure 1.
2. Remove and discard the old cutting wire (E).
3. Place the loops of the new cutting wire (E) onto the eye bolt (F) and the "I" bolt (G).
4. Tighten the wing nuts (H) and the cutting wire (E).

REPLACEMENT PARTS LIST

See Figure 1.

LETTER	PART NO.	DESCRIPTION
E	1838	Cutting Wire (package of 3)
F	1839	Eye Bolt (package of 4)
H	1840	Wing Nut (package of 6)
G	1841	"L" Bolt (package of 4)
Not Shown	1824	Brush

ENGLISH

THIS WARRANTY IS IN LIEU OF ANY OTHER WARRANTIES, EXPRESS OR IMPLIED, INCLUDING ANY IMPLIED WARRANTY OF MERCHANTABILITY OR FITNESS FOR A PARTICULAR PURPOSE

As The Vollrath Company LLC's only responsibility and the purchaser's only remedy, for any breach of warranty, The Vollrath Company LLC will repair or, at its option, replace the defective product or part without charge, except as otherwise provided below:

- For refrigeration compressors and the second year of the warranty on Cayenne® Heat Strips and mixers, The Vollrath Company LLC will provide the repaired or replacement part only; and the buyer will be responsible for all labor charges incurred in performing the repair or replacement.
- To obtain warranty service, the buyer will be responsible to return to The Vollrath Company LLC any product (other than gas equipment that is permanently installed) weighing less than 110 lbs. or located outside of a 50-mile radius of a certified technician designated by The Vollrath Company LLC to perform warranty repairs. If a Vollrath Technician cannot be contacted check the website for service contact points. (Please refer to the Product Catalogue for weights and sizes of product)
- No remedy will be available for products that have been damaged by accident, carelessness, improper installation, lack of proper setup or supervision when required, neglect, improper use, installation or operation contrary to installation and operating instructions or other causes not arising out of defects in materials or workmanship. At the buyer's request, The Vollrath Company LLC will repair and or replace such products at a reasonable cost.
- No remedy will be available for slicers where blade has not been sharpened (Refer to owner's manual for sharpening instructions)
- No remedy will be available for mixers damaged by changing gears while unit is running or overloading, in either case as determined by a Vollrath Certified Technician

(Warranty Continued)

- Warranty work must be authorized in advance by The Vollrath Company LLC. See the operating and safety instructions for each product for detailed warranty claim procedures.
- No remedy will be available for product returned and found to be acceptable to the product specification.
- No remedy will be available under any warranty not registered as required below.

LIMITATION OF LIABILITY:

THE VOLLRATH COMPANY LLC SHALL HAVE NO LIABILITY FOR INCIDENTAL OR CONSEQUENTIAL DAMAGES OF ANY KIND, WHETHER BASED UPON NEGLIGENCE OR OTHER TORT, BREACH OF WARRANTY, OR ANY OTHER THEORY.

WARRANTY PROCEDURE

On all warranty calls, the following process and information is required:

- All warranty claims will start with a call to Vollrath Technical Service support line (800-628-0832).
- A technical support professional will work to diagnose the issues, and provide the details for the service solution.
- Name and phone number of person calling
- Business name, street address, city, state and zip
- Model and serial number
- Date of purchase and proof of purchase (Receipt)
- Name of dealer where unit was purchased

NOTE: Vollrath will not accept products sent without the proper procedure being followed.

Important:

TO MAKE A CLAIM FOR ANY REMEDY UNDER THIS WARRANTY, YOU MUST REGISTER YOUR WARRANTY.

REGISTER TODAY

ONLINE: Register your warranty on-line now at www.Vollrathco.com

NO WEB ACCESS: If you do not have access to the web, kindly register by completing the warranty registration form and faxing it to The Vollrath Co. LLC office in the country of purchase.

WARRANTY REGISTRATION			
BUSINESS NAME			
KEY CONTACT NAME		EMAIL	
STREET ADDRESS			
CITY	STATE	ZIP CODE	
COUNTRY	PHONE	FAX	
MODEL		ITEM NUMBER	
SERIAL NUMBER	-		-
OPERATION TYPE			
<input type="checkbox"/> Limited Service Restaurant	<input type="checkbox"/> Full Service Restaurant	<input type="checkbox"/> Bars and Taverns	<input type="checkbox"/> Supermarket
<input type="checkbox"/> Convenience Store	<input type="checkbox"/> Recreation	<input type="checkbox"/> Hotel/Lodging	<input type="checkbox"/> Airlines
<input type="checkbox"/> Business/Industry	<input type="checkbox"/> Primary/Secondary School	<input type="checkbox"/> Colleges/University	<input type="checkbox"/> Hospitals
<input type="checkbox"/> Long-Term Care	<input type="checkbox"/> Senior Living	<input type="checkbox"/> Military	<input type="checkbox"/> Corrections
REASON FOR SELECTING OUR PRODUCT			
<input type="checkbox"/> Appearance	<input type="checkbox"/> Full Service Restaurant	<input type="checkbox"/> Availability	<input type="checkbox"/> Sellers Recommendation
<input type="checkbox"/> Ease of Operation	<input type="checkbox"/> Versatility of Use	<input type="checkbox"/> Price	<input type="checkbox"/> Brand
WOULD YOU LIKE TO RECEIVE OUR FULL-LINE CATALOG AND REMAIN ON OUR MAILING LIST?			<input type="checkbox"/> Yes <input type="checkbox"/> No



www.vollrathco.com

The Vollrath Company, L.L.C.
1236 North 18th Street
Sheboygan, WI 53081-3201
U.S.A.
Main Tel: 800.628.0830
Service Tel: 800.628.0832
FAX: 800.752.5620

Vollrath of Canada, Co.
Tel: 800.695.8560
FAX: 800.752.5620

© 2010 The Vollrath Company, L.L.C.

