

Operator's Manual

GRINDER



Item	Model	Description	HP	Amps	Voltage	Plug
40743	MIN0012	Grinder No. 12	1 hp	8	110	5-15P
40744	MIN0022	Grinder No. 22	1-1/2 hp	16	110	5-20P

Thank you for purchasing this Vollrath food preparation equipment. Before operating the equipment, read and familiarize yourself with the following operating and safety instructions. **SAVE THESE INSTRUCTIONS FOR FUTURE REFERENCE.** Save the original box and packaging. Use this packaging to ship the equipment if repairs are needed.

SAFETY PRECAUTIONS

To ensure safe operation, read the following statements and understand their meaning. Please read carefully.

WARNING

Warning is used to indicate the presence of a hazard that *can* cause severe personal injury, death, or substantial property damage if the warning is ignored.

CAUTION

Caution is used to indicate the presence of a hazard that *will* or *can* cause *minor* personal injury or property damage if the caution is ignored.

NOTE

Note is used to notify people of installation, operation, or maintenance information that is important but not hazard-related.

For Your Safety!

These precautions should be followed at all times. Failure to follow these precautions could result in injury to yourself and others.

To reduce risk of injury or damage to the equipment:

- Plug only into grounded electrical outlets matching the nameplate rated voltage.
- Do not operate unattended.
- Do not operate equipment in public areas and/or around children.
- Do not use an extension cord with this equipment. Do not plug this equipment into a power strip or multi-outlet power cord.
- Check equipment before each use to insure the equipment is clean.
- Wear proper apparel. Do not wear loose fitting or hanging garments while operating this equipment.
- Use equipment in a flat, level position.
- Unplug equipment, turn off and let it cool before cleaning or moving.
- Do not spray controls or outside of equipment with liquids or cleaning agents.
- Do not clean the equipment with steel wool.
- Keep equipment and power cord away from open flames, electric burners or excessive heat.
- Do not operate if equipment has been damaged or is malfunctioning in any way.

FUNCTION AND PURPOSE

This unit is intended to be used to grind food products and meat for commercial foodservice operations only. It is not intended for household, industrial or laboratory use.

Before using this equipment it must be cleaned and dried thoroughly. Clean all surfaces and parts before use.

UNPACKING THE EQUIPMENT AND INITIAL SETUP

When no longer needed, dispose of all packaging and materials in an environmentally responsible manner.

1. Remove all packing material and tape, as well as any protective plastic from the equipment.
2. Clean any glue residue left over from the plastic or tape.
3. Plug the equipment into a properly grounded electrical supply matching the nameplate rating. Damage to the equipment can occur if incorrect power is supplied to equipment.

FEATURES AND CONTROLS



Figure 1. Features and Controls.

- (A) TRAY. Funnels or flows the food product to the grinder chamber.
- (B) THUMB SCREW. Holds the grinder chamber to the main body.
- (C) MAIN BODY. Houses the motor, switch and other components.
- (D) GRINDER CHAMBER. Grinds the food product and houses the worm gear, blade, grinder plate and coupling cover nut.
- (E) COUPLING COVER NUT. Holds the grinder plate in place.
- (F) CONTROL SWITCH. Switches the motor to “FORWARD”, “REVERSE” or “OFF”.
- (G) RESET BUTTON. If the grinder becomes overloaded this button needs to be manually reset after allowing the unit to cool.
- (H) FOOD PUSHER. Used to push the food product into the grinder chamber.

OPERATION

	WARNING
	<p>Entanglement Hazard. Never place fingers, hands or other objects into the feed chute other than the food pusher provided with the appliance. Injury and product damage will occur.</p>

	WARNING
	<p>Electrical Shock Hazard. Keep water and other liquids from entering the inside of the equipment. Liquid inside the equipment could cause an electrical shock.</p>



1. Before grinding, verify the grinder chamber (D) is seated correctly on the main body (C) and tighten the thumbscrew (B) counter-clockwise until secure. See Figure 1.

NOTE:

Do not use a tool to tighten the thumbscrew. Hand tighten only.

2. Tighten the coupling cover nut (E) against the grinder chamber securely.
3. Prepare the food product. For vegetables remove stalks and stems or for meat, remove all the skin and bones.
4. Cut the food product into appropriately sized pieces for grinding.
5. Place the tray (A) on the top of grinder chamber (D).
6. Turn the control switch (F) to the "Forward" position.
7. Use the food pusher (H) to push the food product into grinder chamber (D). Never use fingers, hands or other objects. Feed the food product and grind slowly at a rate that the grinder will accept. Do not force too much product into the grinder chamber. It can overload the grinder causing it to stop.
8. When grinding session is over turn the control switch (F) to the "OFF" position.

NOTE:

If the unit becomes jammed or the discharge is erratic, turn the switch to the "OFF" position. Switch to the "Reverse" position momentarily, turn the unit to the "OFF" position. Check the following:

- Thumb screw too tight; loosen and hand-tighten, do not over-tighten
- Discharge plate is blocked; remove and clear
- Blade edges are dull; have sharpened or replace
- Overloading and motor stops; switch too and reset.
- Blade is in backwards.

CLEANING

To maintain the appearance and increase the service life, clean your equipment daily.

Grinder Chamber Removal and Disassembly

1. Turn the control switch to the "OFF" position and unplug from its power source.
2. Unscrew and remove the coupling cover nut (A) from the grinder chamber (B). See Figure 2.

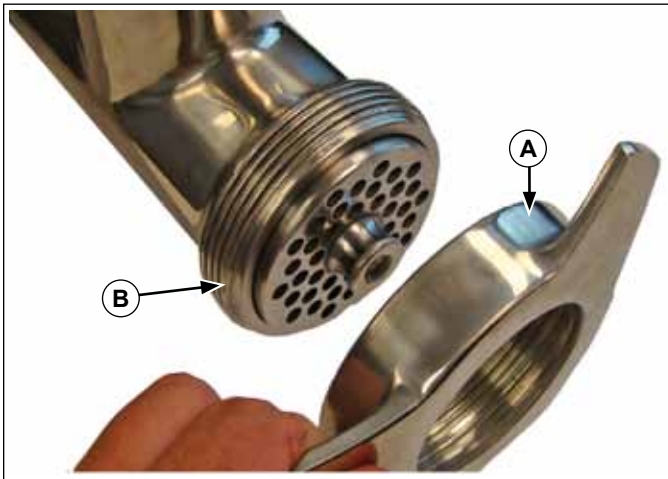

Figure 2. Coupling Cover and Grinder Chamber

3. Remove the grinder plate (D) from the blade shaft (A). See Figure 3.

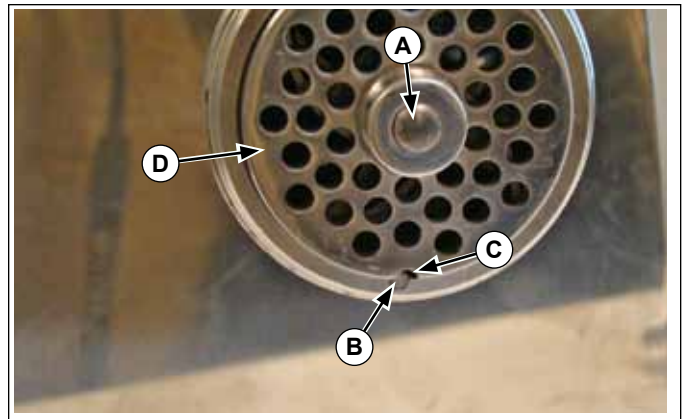

Figure 3. Grinder Plate, Cutout, Locating Pin and Blade Shaft

4. Carefully remove the knife blade (B) from the blade shaft (C). See Figure 4.

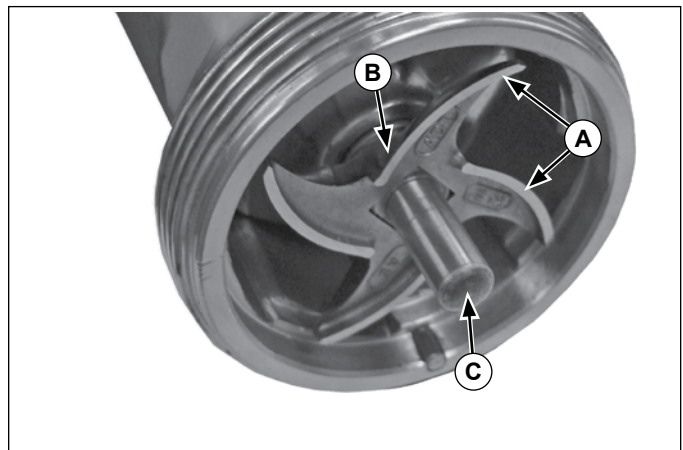

Figure 4. Knife Blade and Blade Shaft

5. Remove the worm gear assembly (B) from the grinder chamber (C). See Figure 5.

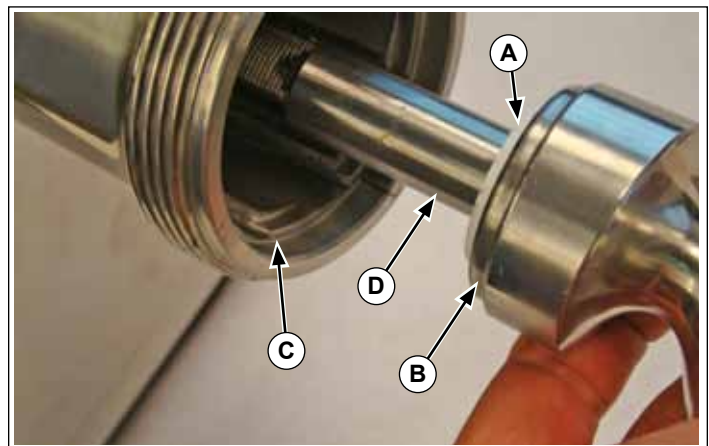

Figure 5. Shaft Washer, Worm Gear Assembly and Grinder Chamber

6. Remove the shaft washer (A) from the worm gear shaft (B). See Figure

ENGLISH

6.

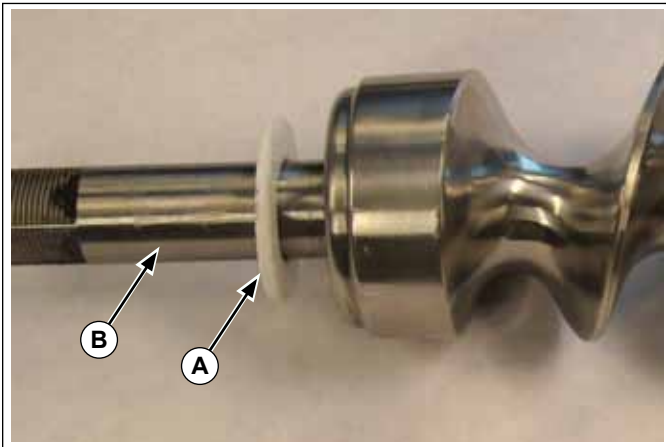

Figure 6. Shaft Washer and Worm Gear Shaft

7. If desired remove the blade shaft assembly (B) from the worm gear (A). See Figure 7

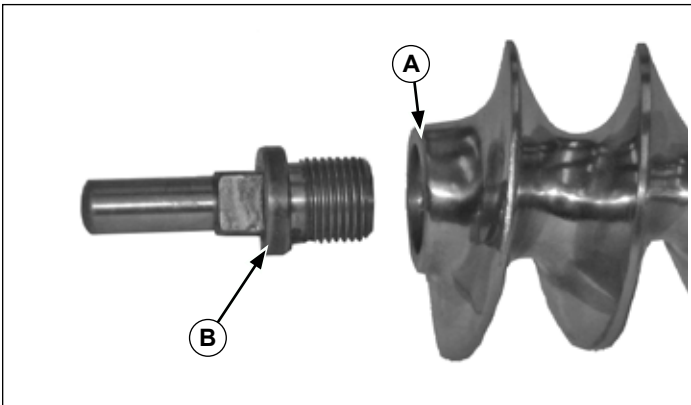

Figure 7. Blade Shaft and Worm Gear

Thoroughly clean and dry all parts.

Grinder Chamber Assembly and Installation

1. If necessary assemble the blade shaft (B) into the worm gear (A). See Figure 7.
2. Slide the shaft washer (A) onto the worm gear shaft (B). See Figure 6.
3. Slide the shaft washer (A) so that it is seated against the worm gear assembly (B) as shown. See Figure 5.
4. Slide the worm gear assembly (B) and the shaft washer (A) into the grinder chamber (C). Slide the worm gear shaft (D) in until it is seated fully.
5. Slide the knife blade (B) so that the flat ground edges (A) face to the outside as shown, onto the blade shaft (C). See Figure 8.

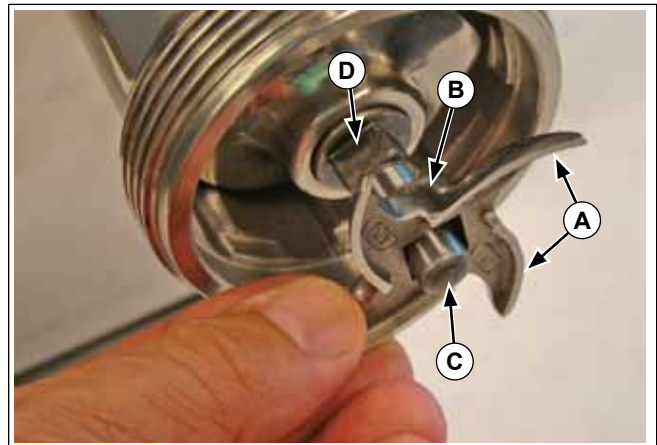

Figure 8. Knife Blade and Blade Shaft Figure

6. Slide the knife blade (B) onto the blade shaft (C) so that it seats completely over the square (D). See Figure 4.
7. Place the grinder plate (D) onto the blade shaft (A) so that the cutout (C) slides over the locating pin (B). See Figure 3.
8. If a sausage filler is to be used, place it between the coupling cover (A) and the grinder chamber (B). See Figure 2.
9. Thread the coupling cover (A) onto the grinder chamber (B) and tighten securely.

TROUBLESHOOTING

Problem	Possible Cause	Course of Action
Grinder stops operating or output is erratic.	Grinder is overloaded.	Switch to the "Reverse" position momentarily, turn the unit to the "OFF" position. Check the following: <ul style="list-style-type: none"> ■ Thumb screw too tight; loosen and hand-tighten, do not over-tighten ■ Discharge plate is blocked; remove and clear ■ Blade edges are dull; have sharpened or replace Press the reset button.
Grinder stops operating or output is erratic.	Blades are in backwards.	Correct blade direction.
Metal shavings or particles in food product.	Blades are in backwards.	Correct blade direction.
Motor humms but does not operate.	Governor out of adjustment.	Adjust governor per procedures posted at Vollrathco.com or contact Vollrath Technical Service.

SERVICE AND REPAIR

There are no user serviceable parts within this appliance. To avoid serious injury or damage, never attempt to repair the equipment or replace a damaged power cord yourself. Do not send equipment directly to the Vollrath Company. Please contact the qualified professional repair service listed below.

VOLLRATH Technical Service • 1-800-628-0832



ELECTRICAL DRAWING - GRINDER ~ 40743

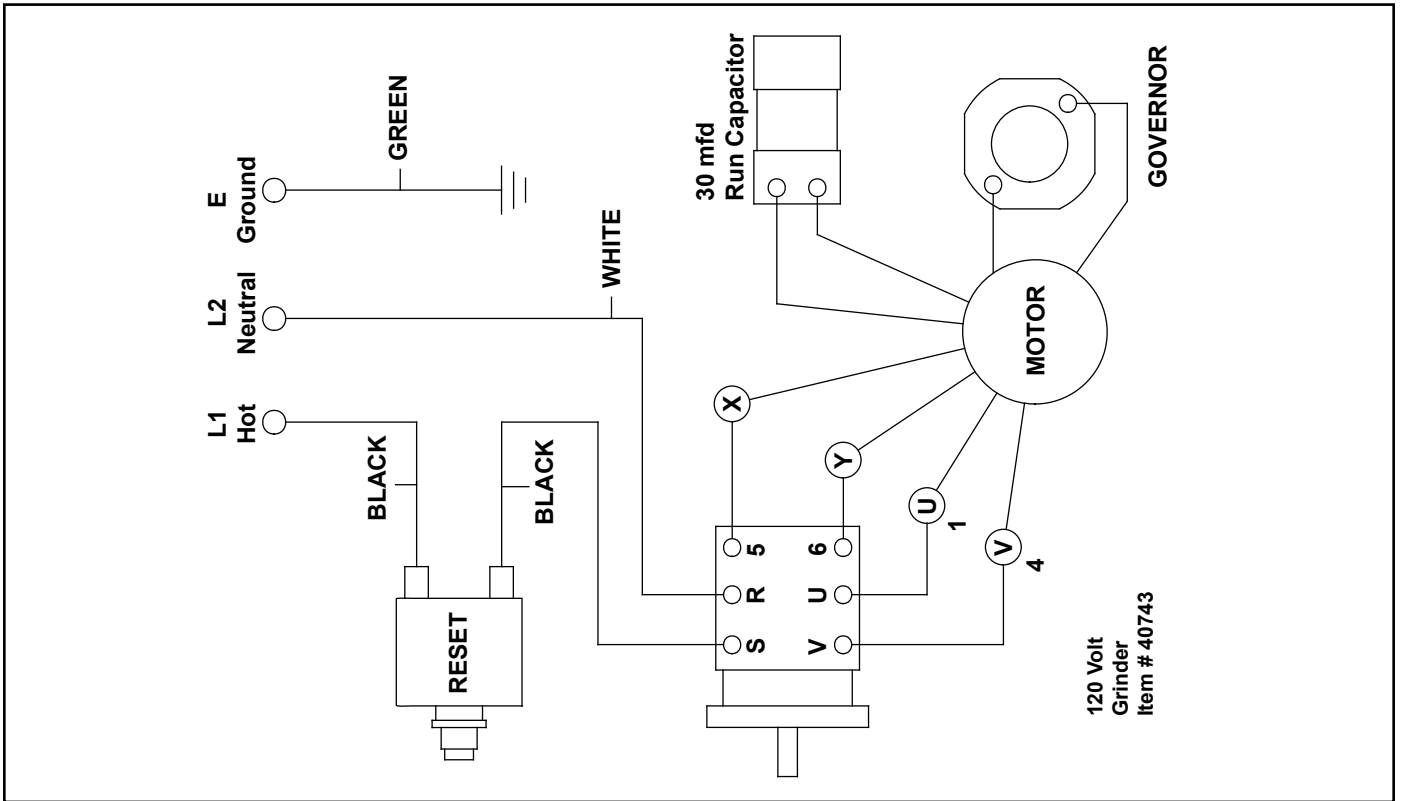

ELECTRICAL DRAWING - GRINDER ~ 40744

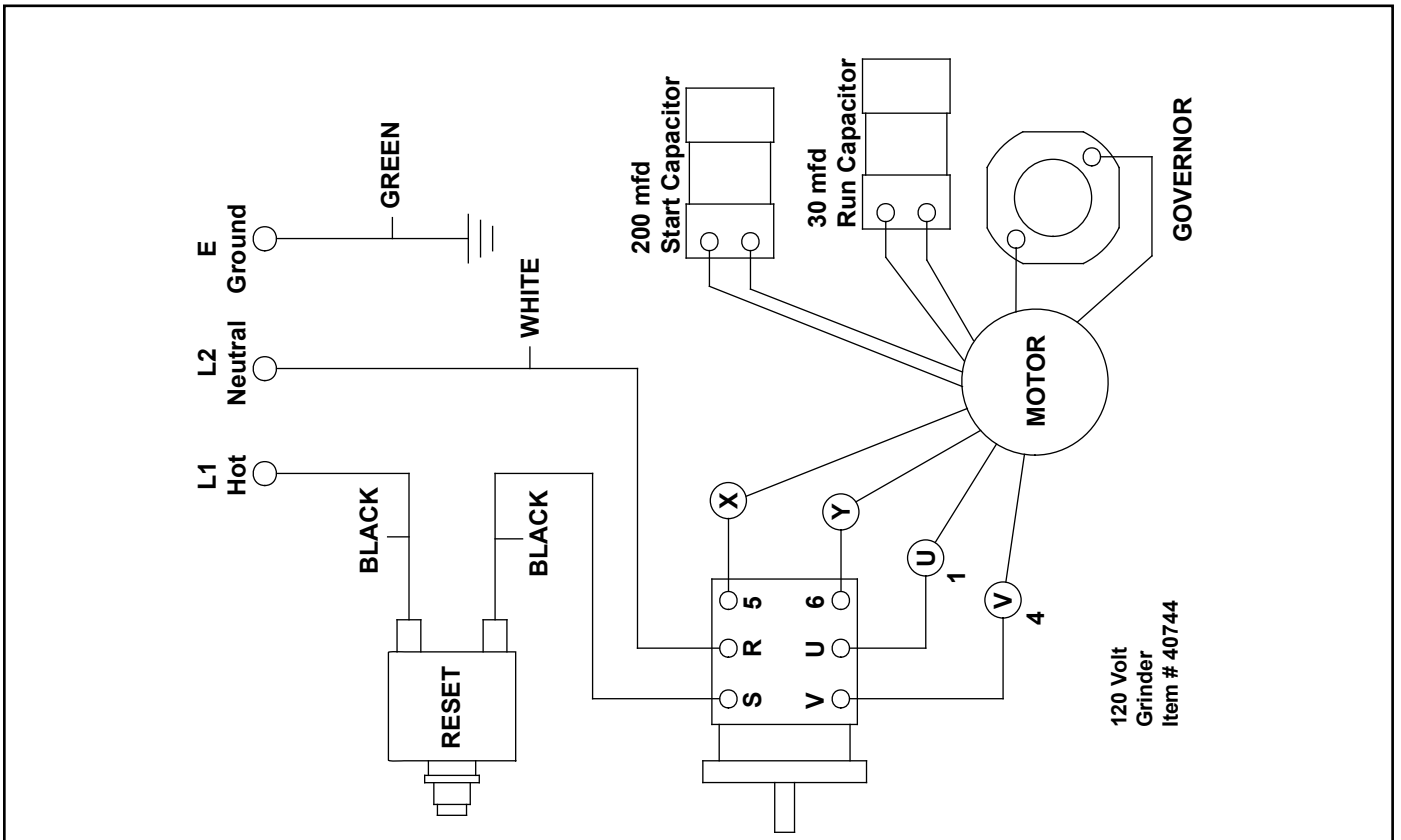

ENGLISH

EXPLODED VIEW DRAWING - GRINDER ~ 40743

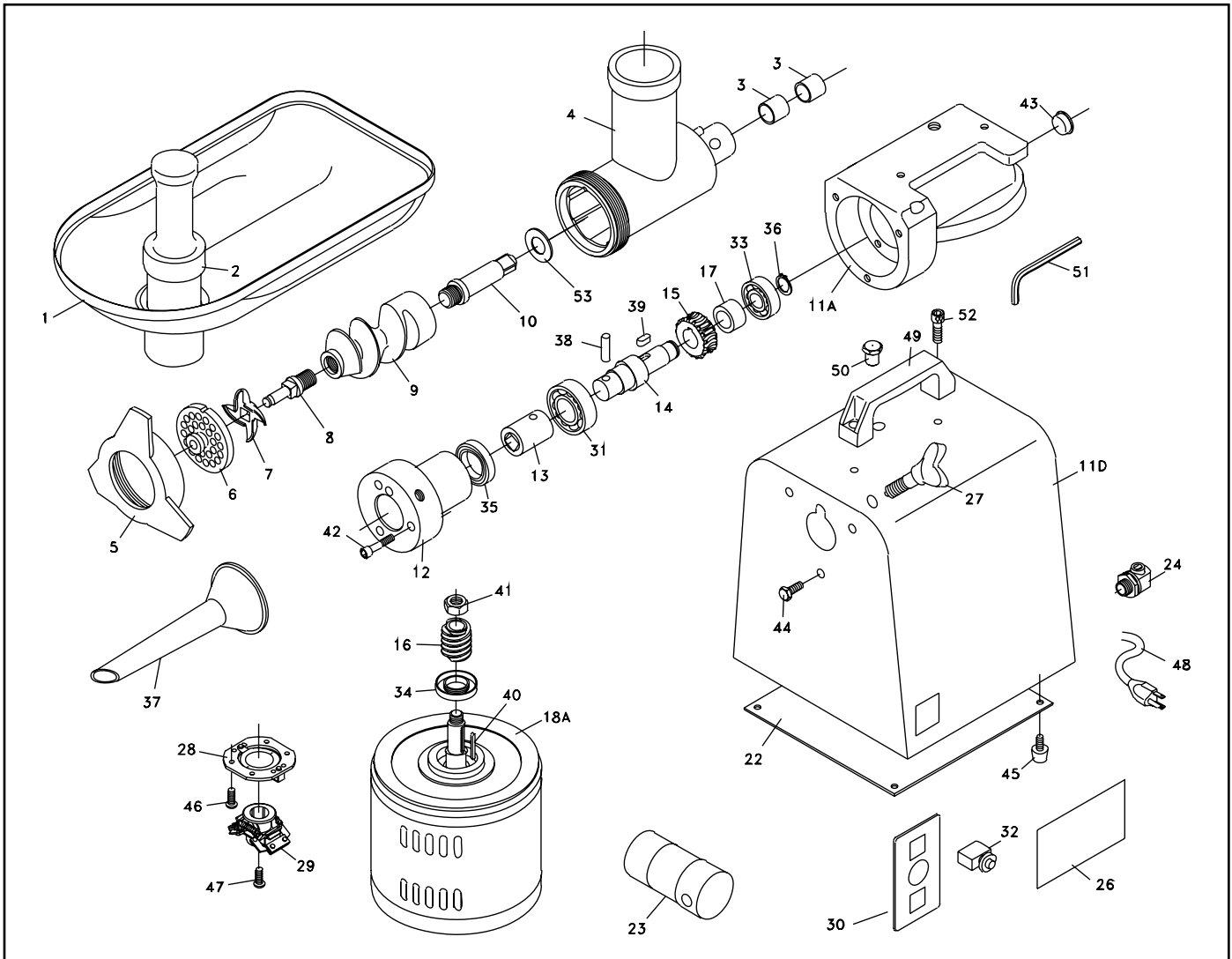

SPARE PARTS LIST - GRINDER ~ 40743

Callout	Part Number	Description
1	XMIN1224	FEEDER PAN
2	XMIN2202	MEAT PUSHER
3	XMIN1226	BRASS BUSH FOR CHAMBER
4	XMIN1204	GRINDING CHAMBER HEAD
5	XMIN1203	COUPLING COVER NUT
6	40747	PLATE 1/8" (was XMIN1207)
6	40748	PLATE 1/4" (was XMIN1208)
6	40749	PLATE 1/2" (was XMIN1209)
7	40746	GRINDER KNIFE (was XMIN1206)
8	XMIN1232	WORM SHAFT FRONT
9	N/A	WORM
10	XMIN1231	WORM SHAFT REAR
8/9/10	XMIN1205	WORM (SPIRAL PROPELLER ASSEMBLY)
11A	XMIN1210	GEARBOX COMPLETE (#11A,12,13,14,15,17,31,33,35,36,38,39,42,43)
15	XMIN1218	BRASS WORM GEAR
16	XMIN1222	WORM DRIVE GEAR SPIRAL
18A	XMIN1221	MOTOR
22	XMIN1219	PLASTIC BASE PLATE
23	XMIN1212	CAPACITOR, 200mfd 125V AC
24	XAA0012	CABLE RESTRAINT
27	XMIN1213	THUMBSCREW
28	XMIX2004	GOVERNOR PLATE
29	XMIN1215	GOVERNOR
30	XMIN1216	ON/OFF SWITCH
31	XMIX3086	BEARING, 6205Z
32	XMIN1225	RESET SWITCH
33	XSL6203	BEARING, 6203
35	XMIN2230	OIL SEAL, 30 X 45 X 8
36	N/A	CIRCLIP A15
37	XMIN1217	MEAT FUNNEL
39	XMIN1230	KEY, (6X6X15)
42	N/A	HEX BOLT
43	XMIX2290	FREEZE PLUG
45	XMIN1220	FEET
48	XAA0005	POWERCORD, 120V, NEMA5-15P PLUG
49	XMIN1229	PLASTIC HANDLE
50	XMIN1223	GREASE TRAPPER BOLT
52	XMIN1228	HANDLE HEXBOLT
53	XMIN1211	SPACER

ENGLISH

EXPLODED VIEW DRAWING - GRINDER ~ 40744

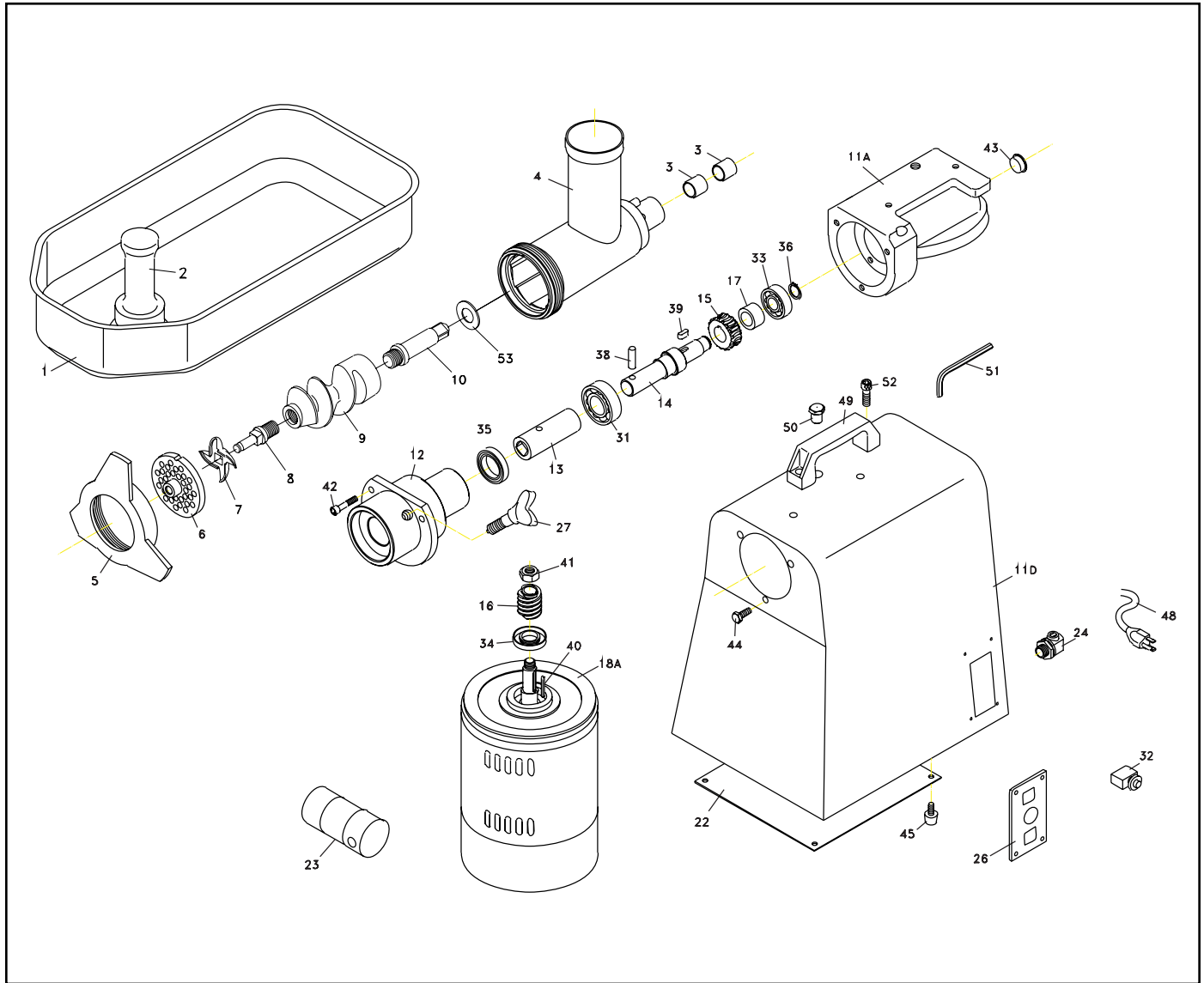

SPARE PARTS LIST - GRINDER ~ 40744

Callout	Part Number	Description
1	XMIN2223	FEEDER PAN
2	XMIN2202	MEAT PUSHER
4	XMIN2204	GRINDING CHAMBER
5	XMIN2203	COUPLING COVER NUT
6	40751	PLATE 1/8" (was XMIN2207)
6	40752	PLATE 1/4" (was XMIN2208)
6	40753	PLATE 1/2" (was XMIN2209)
7	40750	GRINDER KNIFE (was XMIN2206)
8/9/10	XMIN2205	WORM/ SPIRAL PROPELLER
11A	XMIN2210	GEARBOX COMPLETE (#11A,12,13, 14,15,17,31,33,35,36,38,43)
12	XMIN2219	FRONT HUB
15	XMIN2220	BRASS WORMGEAR
16	XMIN2228	WORM GEAR SPIRAL
18A	XMIN2229	MOTOR
22	XMIN2221	PLASTIC BASE COVER
23	XMIN2212	RUN CAPACITOR, 400mfd, 125V AC
24	XAA0012	CABLE RESTRAINT
27	XMIN1213	THUMBSCREW
Not Shown	XMIX4004	GOVERNOR PLATE
Not Shown	XMIN1215	GOVERNOR
30	XMIN1216	ON/OFF SWITCH
31	XMIX3086	BEARING, 6205Z
32	XMIN2225	RESET SWITCH
33	XSL6203	BEARING, 6203
34	N/A	CIRCLIP, A15
35	XMIN2230	GEARBOX OIL SEAL (TC30X45X8))
37	XMIN2217	MEAT FUNNEL
39	XMIN1230	KEY (6X6X15)
43	XMIX2290	FREEZE PLUG
45	XMIN1220	FEET
48	XAA0006	POWERCORD, 220V, NEMA6-15P
49	XMIN1229	PLASTIC HANDLE
50	XMIN1223	GREASE TRAPPER BOLT
52	XMIN1228	HANDLE HEXBOLT
53	XMIN1211	SPACER

ENGLISH

WARRANTY STATEMENT FOR THE VOLLRATH Co. L.L.C.

The Vollrath Company LLC warrants the products it manufactures and distributes against defects in materials and workmanship for a period of one year, except as specifically provided below. The warranty runs 12 months from the date of original installation. (End user receipt)

1. Refrigeration compressors – The warranty period is 5 years.
2. Replacement parts – The warranty period is 90 days.
3. Fry pans and coated cookware – The warranty period is 90 days
4. EverTite™ Riveting System – The warranty covers loose rivets only, forever.
5. Cayenne® Heat Strips – The warranty period is 1 year plus an additional 1 year period on heating element parts only.
6. Ultra and Professional Induction Ranges – The warranty period is 2 years.
7. Mirage and Commercial Induction ranges - The warranty period is 1 year.
8. ServeWell® Induction Workstations – The warranty period is one year on the workstation table and 2 years on induction hobs.
9. Slicers – The warranty period is 10 years on gears and 5 years on belts.
10. Mixers – The warranty period is 2 years.
11. Extended warranties are available at the time of sale.
12. Vollrath – Redco products – The warranty period is 2 years.
13. Optio / Arkadia product lines – The warranty period is 90 days.
14. All non-stick products (i.e. fry pans and surfaces) are 90 days for the non stick surfaces.

All products in the Jacob's Pride® collection, including the following, have a lifetime warranty:

- NSF Certified One-Piece Dishers
- NSF Certified Spoodle® Utensils
- NSF Certified Heavy-Duty Spoons with Ergonomic Handle
- NSF Certified Heavy-Duty Basting Spoons
- Heavy duty Turners with Ergonomic handle
- One-Piece Tongs*
- Heavy-Duty One-Piece Ladles*
- Nylon Handle Whips
- One-Piece Skimmers
- Tribute®, Intrigue®, and Classic Select® Cookware*

*Jacob's Pride® warranty does not cover Kool-Touch®, non stick coatings and silicone handles.

Items sold having no warranty:

- Meat Grinder Knives
- Light Bulbs in Convection Ovens and Hot Food Merchandiser
- Oven Door Seals
- Oven Door Glass
- Hot Food Merchandisers / Display Case Glass
- Calibration and set up of gas equipment
- Slicer / Dicer blades (table top food prep) – Redco and Vollrath

THIS WARRANTY IS IN LIEU OF ANY OTHER WARRANTIES, EXPRESS OR IMPLIED, INCLUDING ANY IMPLIED WARRANTY OF MERCHANTABILITY OR FITNESS FOR A PARTICULAR PURPOSE

As The Vollrath Company LLC's only responsibility and the purchaser's only remedy, for any breach of warranty, The Vollrath Company LLC will repair or, at its option, replace the defective product or part without charge, except as otherwise provided below:

- For refrigeration compressors and the second year of the warranty on Cayenne® Heat Strips and mixers, The Vollrath Company LLC will provide the repaired or replacement part only; and the buyer will be responsible for all labor charges incurred in performing the repair or replacement.
- To obtain warranty service, the buyer will be responsible to return to The Vollrath Company LLC any product (other than gas equipment that is permanently installed) weighing less than 110 lbs. or located outside of a 50-mile radius of a certified technician designated by The Vollrath Company LLC to perform warranty repairs. If a Vollrath Technician cannot be contacted check the website for service contact points. (Please refer to the Product Catalogue for weights and sizes of product)
- No remedy will be available for products that have been damaged by accident, carelessness, improper installation, lack of proper setup or supervision when required, neglect, improper use, installation or operation contrary to installation and operating instructions or other causes not arising out of defects in materials or workmanship. At the buyer's request, The Vollrath Company LLC will repair and or replace such products at a reasonable cost.
- No remedy will be available for slicers where blade has not been sharpened (Refer to owner's manual for sharpening instructions)
- No remedy will be available for mixers damaged by changing gears while unit is running or overloading, in either case as determined by a Vollrath Certified Technician
- Warranty work must be authorized in advance by The Vollrath Company LLC. See the operating and safety instructions for each product for detailed warranty claim procedures.
- No remedy will be available for product returned and found to be acceptable to the product specification.
- No remedy will be available under any warranty not registered as required below.

LIMITATION OF LIABILITY:

THE VOLLRATH COMPANY LLC SHALL HAVE NO LIABILITY FOR INCIDENTAL OR CONSEQUENTIAL DAMAGES OF ANY KIND, WHETHER BASED UPON NEGLIGENCE OR OTHER TORT, BREACH OF WARRANTY, OR ANY OTHER THEORY.



WARRANTY PROCEDURE

On all warranty calls, the following process and information is required:

- All warranty claims will start with a call to Vollrath Technical Service support line.(800-628-0832).
- A technical support professional will work to diagnose the issues, and provide the details for the service solution.
- Name and phone number of person calling
- Business name, street address, city, state and zip
- Model and serial number
- Date of purchase and proof of purchase (Receipt)
- Name of dealer where unit was purchased

NOTE: Vollrath will not accept products sent without the proper procedure being followed.

Important:

TO MAKE A CLAIM FOR ANY REMEDY UNDER THIS WARRANTY, YOU MUST REGISTER YOUR WARRANTY.

REGISTER TODAY

ONLINE: Register your warranty on-line now at www.Vollrathco.com

NO WEB ACCESS: If you do not have access to the web, kindly register by completing the warranty registration form and faxing it to The Vollrath Co. LLC office in the country of purchase.

WARRANTY REGISTRATION			
BUSINESS NAME			
KEY CONTACT NAME		EMAIL	
STREET ADDRESS			
CITY	STATE	ZIP CODE	
COUNTRY	PHONE	FAX	
MODEL		ITEM NUMBER	
SERIAL NUMBER	-	-	
OPERATION TYPE			
<input type="checkbox"/> Limited Service Restaurant	<input type="checkbox"/> Full Service Restaurant	<input type="checkbox"/> Bars and Taverns	<input type="checkbox"/> Supermarket
<input type="checkbox"/> Convenience Store	<input type="checkbox"/> Recreation	<input type="checkbox"/> Hotel/Lodging	<input type="checkbox"/> Airlines
<input type="checkbox"/> Business/Industry	<input type="checkbox"/> Primary/Secondary School	<input type="checkbox"/> Colleges/University	<input type="checkbox"/> Hospitals
<input type="checkbox"/> Long-Term Care	<input type="checkbox"/> Senior Living	<input type="checkbox"/> Military	<input type="checkbox"/> Corrections
REASON FOR SELECTING OUR PRODUCT			
<input type="checkbox"/> Appearance	<input type="checkbox"/> Full Service Restaurant	<input type="checkbox"/> Availability	<input type="checkbox"/> Sellers Recommendation
<input type="checkbox"/> Ease of Operation	<input type="checkbox"/> Versatility of Use	<input type="checkbox"/> Price	<input type="checkbox"/> Brand
WOULD YOU LIKE TO RECEIVE OUR FULL-LINE CATALOG AND REMAIN ON OUR MAILING LIST?			<input type="checkbox"/> Yes <input type="checkbox"/> No

ENGLISH



www.vollrathco.com

The Vollrath Company, L.L.C.
1236 North 18th Street
Sheboygan, WI 53081-3201
U.S.A.

Main Tel: 800.628.0830
Fax: 800.752.5620

Technical Services: 800.628.0832
Service Fax: 920.459.5462

Canada Service: 800.695.8560

© 2014 The Vollrath Company, L.L.C.

