



Outperform every day.™

Operator's Manual

Heavy-Duty Electric Deli Slicers



Item No.	Model No.	Description	Drive	Peak HP	Voltage	Amps	Hz	Plug
40955	SLM330E/S	13" Blade	Belt	1/2	120	2.0	60	NEMA 5-15P

Thank you for purchasing this Vollrath equipment. Before operating the equipment, read and familiarize yourself with the following operating and safety instructions. **SAVE THESE INSTRUCTIONS FOR FUTURE REFERENCE.** Save the original box and packaging. Use this packaging to ship the equipment if repairs are needed.

SAFETY PRECAUTIONS

To ensure safe operation, read the following statements and understand their meaning. This manual contains safety precautions which are explained below. Please read carefully.

WARNING

Warning is used to indicate the presence of a hazard that will or can cause severe personal injury or death.

CAUTION

Caution is used to indicate the presence of a hazard that will or can cause minor or major personal injury if the caution is ignored.

NOTICE: Notice is used to note information that is important but not hazard-related.

WARNING

Severe injury can occur if this equipment is not used properly.

To reduce risk of injury or damage to the equipment:

- Keep out of reach of children.
- Do not turn equipment on unless all guards are in place.
- Do not feed food by hand: always use food pusher.
- Equipment must be connected to a properly grounded electrical supply matching the nameplate rating.
- Always unplug equipment before cleaning.
- Keep equipment away from water; avoid water jets during cleaning.
- Equipment should only be used in a flat, level position.
- Do not operate unattended.
- Install or locate this appliance only in accordance with the provided installation instructions.
- Do not operate this appliance if it has a damaged cord or a plug, if it is not working properly or if it has been damaged or dropped.
- Do not immerse the cord or plug in water. Keep the cord away from heated surfaces. Do not let the cord hang over the edge of a table or counter.
- Do not use an extension cord with this equipment. Do not plug this equipment into a power strip or multi-outlet power cord.
- Have a qualified personnel install this equipment in accordance with local codes and ordinances.
- Do not spray controls or outside of equipment with liquids or cleaning agents.
- Do not clean the equipment with steel wool.
- Keep equipment and power cord away from open flames, electric burners or excessive heat.

Please register your product at Vollrath.com

FUNCTION AND PURPOSE

This equipment is intended to be used to slice food products in commercial foodservice operations only. It is not recommended for use with bone-in meat. It is not intended for household or laboratory use.

RECEIVING AND UNCRATING THE EQUIPMENT

1. Upon arrival, inspect the package and equipment for damage.
2. Immediately inform the carrier of any damage.
3. Position the pallet with the slicer on a flat surface.

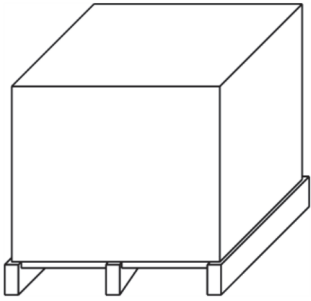

4. Remove all packing material and tape, as well as any protective plastic from the equipment.

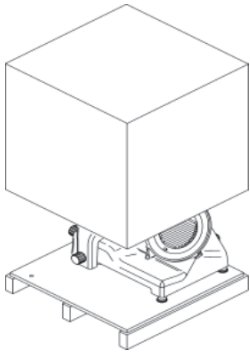

5. Remove the sharpener. See “Disassemble the Slicer” on page 5.

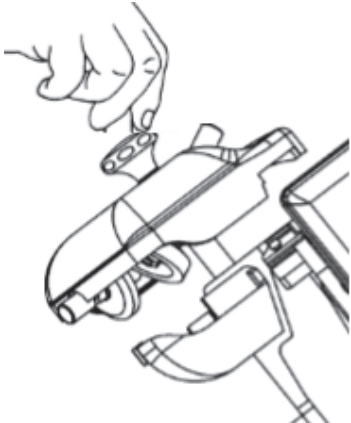

6. Gently turn the slicer so it is resting on the blade cover knob.

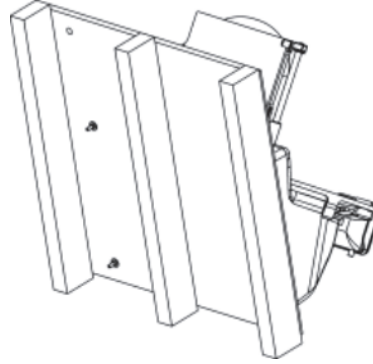

7. Remove the four nuts that fasten the slicer to the pallet. Remove the four washers and unscrew the four fastening tie rods from the pallet.

NOTICE: Take care to support the slicer so it does not tip when the fastening hardware is removed.

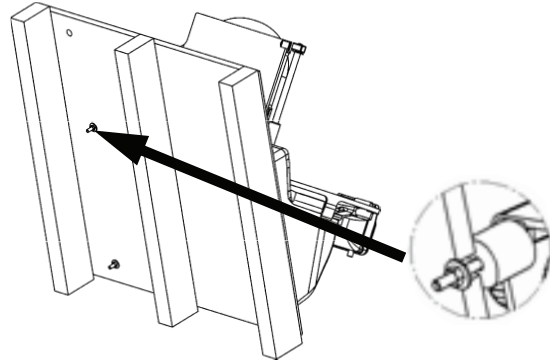

8. Remove the pallet.
9. Install the metal spacers and rubber feet.

NOTICE: Feet and spacers must be installed to meet agency listing criteria.

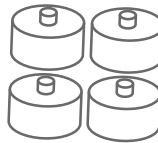

10. Upright the slicer and set on its feet.
11. Turn the feet to level the slicer.

SET UP THE EQUIPMENT

Clearance and Environmental Requirements

Slicer must be placed:

- 31-1/2" (80 cm) from the ground
- 7-7/8" (20 cm) from walls or surrounding objects to allow for sufficient room to operate the slicer
- in a dry area, away from heat sources and not in a passageway.

Set Up

1. Clean the equipment.
Before using this equipment it must be cleaned thoroughly. See "Clean and Sanitize the Slicer" on page 5. Failure to clean surfaces before using the equipment could cause food contamination.
2. Plug the equipment into a properly grounded electrical supply matching the nameplate rating. Damage to the equipment can occur if incorrect power is supplied to equipment.

FEATURES AND CONTROLS

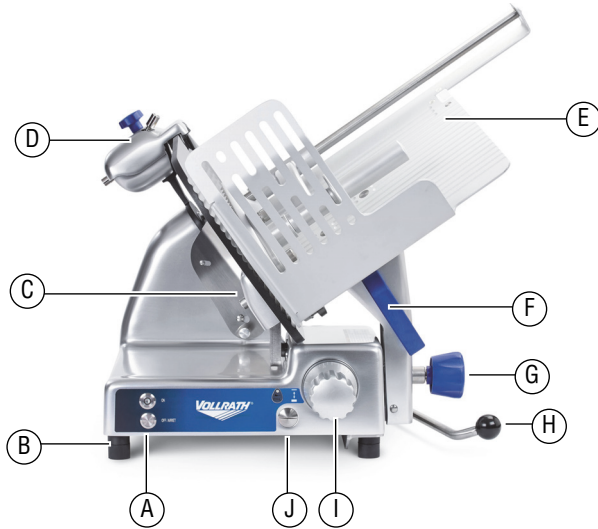

- A ON and OFF Buttons
- B Foot (metal spacers not shown)
- C Slice Guard
- D Blade Sharpener
- E Carriage Tray
- F Carriage Handle
- G Carriage Release Knob
- H Kickstand

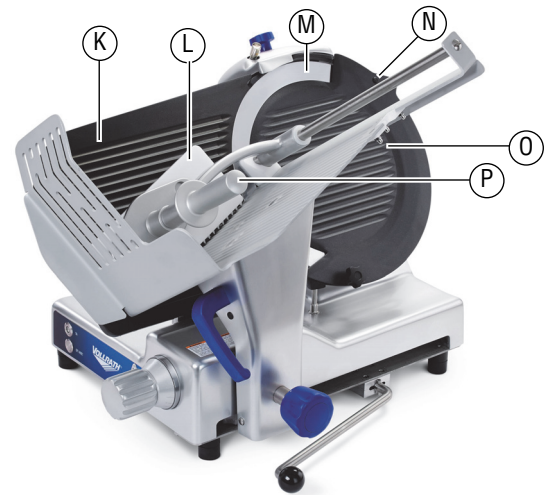

- I Index Control Knob
- J Carriage Slide Lubricant Access
- K Gauge Plate
- L Product Grip
- M Blade
- N Blade Cover Release Knob
- O Blade Cover
- P Product Grip Handle

Safe Blade Removal Tool (Not Pictured). See "Safe Blade Removal Tool" on page 7.

OPERATION



WARNING

Cut and Amputation Hazard

The blade on this commercial slicer is extremely sharp. Severe injury can occur if care is not used when using or cleaning this product. Only trained personal should operate equipment or perform maintenance. To reduce the risk of injury, the use of a cut resistant glove(s) is recommended when cleaning this equipment.



WARNING

Electrical Shock Hazard

Keep water and other liquids from entering the inside of the equipment. Liquid inside the equipment could cause an electrical shock. Do not spray water or cleaning products. Liquid could contact the electrical components and cause a short circuit or an electrical shock.

Before you Begin

Inspect the slicer to verify all components are installed. Do not use the slicer if the components are not in good condition. Contact an authorized Vollrath service agency to service the slicer.

Load the Slicer

1. Slide the carriage tray to the load/start position (closest to the operator).
2. Lift the product grip and place the food onto the carriage tray and in contact with the gauge plate.
3. Place the product grip either on top or behind the food to be sliced.
4. Set the desired slice thickness using the indexing control.
5. Press and release the ON (—) button.

Slice Food

1. Use the carriage handle to push the carriage tray back and forth to slice the food.

Turn Off Slicer

1. Turn the index control to the zero (0) position so the gauge plate protects the blade edge.
2. Press and release the OFF (O) button.

OVERLOAD RESET SWITCH

If the slicer becomes overloaded the reset switch stops the slicer to protect the motor. In case of overload:

1. Press and release the OFF (O) button.
2. Remove the food that caused the overload. If necessary, clean the equipment. See “Clean and Sanitize the Slicer” on page 5.
3. Press and release the reset button, located on the bottom of the slicer.



4. Press and release the ON (—) button to resume operation.

Reset should be a rare occurrence and should be due to overloading the slicer. Contact a Vollrath authorized repair service center if the switch is activating often during normal use.

CLEAN AND SANITIZE THE SLICER



WARNING

Cut and Amputation Hazard

The blade on this commercial slicer is extremely sharp. Severe injury can occur if care is not used when using or cleaning this product. Only trained personal should operate equipment or perform maintenance. To reduce the risk of injury, the use of a cut resistant glove(s) is recommended when cleaning this equipment.



WARNING

Electrical Shock Hazard

Keep water and other liquids from entering the inside of the equipment. Liquid inside the equipment could cause an electrical shock. Do not spray water or cleaning products. Liquid could contact the electrical components and cause a short circuit or an electrical shock.

NOTICE: This slicer shall be cleaned and sanitized at intervals to comply with national, state and/or local health codes.

NOTICE: This slicer shall be cleaned and sanitized each time the blade is sharpened.

Disassemble the Slicer

1. Unplug the slicer from the electrical outlet.
2. Turn the index control knob to the right, past zero (0), until it will not turn any further. This positions the gauge plate to protect you from the blade and is required for the carriage tray to be locked.
3. Remove the product grip handle. Note on some models, the handle is not removable.

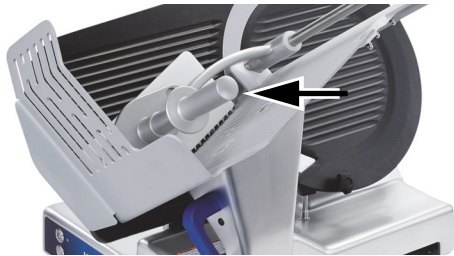

4. Turn the carriage tray release knob until it is very loose. Note: it is not removable.



5. Use the carriage handle to firmly pull (do not force) the carriage tray forward until you hear a click and it is locked into place. If it is difficult to lock the carriage tray, verify the index control knob is turned past zero and as far as possible to the right. Further loosen the carriage release knob.



6. Tilt the carriage to the side.

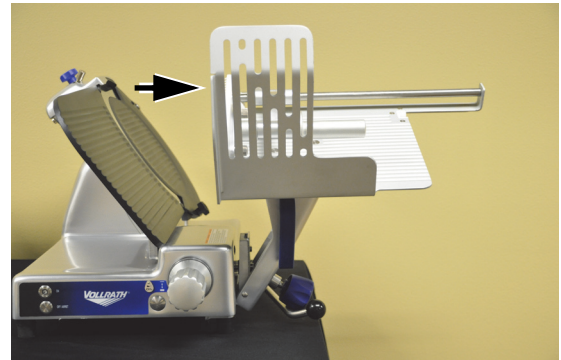

7. Pull the blade cover knob to release the cover from the blade.



8. Lift the blade sharpening assembly and rotate it 90° counter clockwise. Lift to remove it.



9. Remove the slice guard.

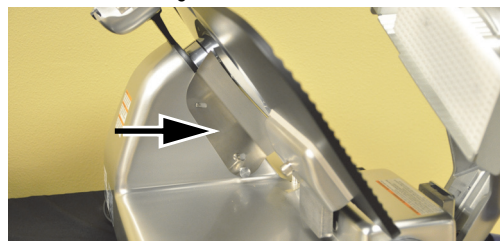

10. Use a clean cloth to remove all coarse residual food and liquid from the slicer surfaces.

CLEAN AND SANITIZE THE SLICER (CONTINUED)

Clean the Slicer

NOTICE: Do not clean the equipment with abrasive materials or scratching cleansers. These can damage the finish. Clean the slicer with only water, a mild detergent and sanitizing solution.

NOTICE: Hand wash only.

1. Wash the removable parts in a clean basin filled with a solution of clean warm water and mild detergent.
2. Rinse the parts with clean warm water.
3. Use a soft cloth, clean warm water and a mild detergent to clean the non-removable parts of the slicer:
 - The front and back sides of the blade. Start at the center of blade and wipe toward the edge.



- Blade guard. From the backside of the blade guard, carefully wipe the inside edge of the guard.
- Gauge plate. Start at the blade and wipe outward.



- Body of the slicer.

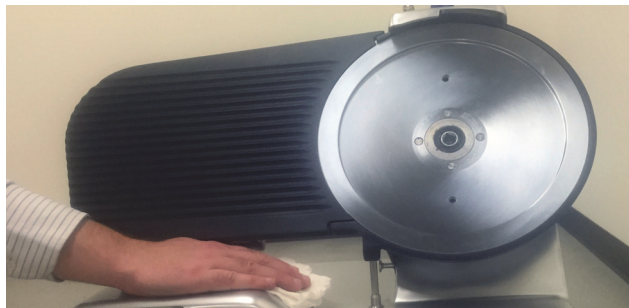

- Underneath the slicer. Use the kickstand to lift the slicer.



4. Rinse the non-removable parts of the slicer with clean warm water.

Sanitize the Slicer

NOTICE: The sanitizer concentration shall comply with Section 4-501.114, Manual and Mechanical Warewashing Equipment, Chemical Sanitization – Temperature, pH, Concentration, and Hardness of the FDA Food Code.

NOTICE: If a chemical sanitizer other than chlorine, iodine or quaternary ammonium is used, it shall be applied in accordance with the EPA registered label use instruction.

1. Wash your hands.
2. Soak the removable parts in a clean basin or sink, in a solution of clean warm water and correctly diluted sanitizing solution.
3. Remove the parts from the basin and allow them to air dry. Do not remove the sanitizer.
4. Moisten a soft clean cloth with correctly diluted sanitizing solution.
5. Use the cloth to sanitize the non-removal parts and body of the slicer. See Step 3 under “Clean the Slicer.” Do not remove the sanitizer.

Reassemble the Slicer

1. Verify the index control knob is at the zero (0) position.
2. Install the slice guard.
3. Install the blade cover knob and secure the blade cover.
4. Install the carriage tray and tighten the carriage tray release knob.
5. Install the blade sharpening assembly.
6. Tighten the blade sharpening knob.
7. Install the product grip handle.

Inspect the Slicer

- Inspect the slicer for correct assembly and verify the slicer is in good working condition.
- Do not use the slicer if it is not in good working condition. Contact an authorized Vollrath service agency to service the equipment.

SAFE BLADE REMOVAL TOOL

1. Remove the blade guard cover.
2. Clean the front side of the blade. See “Clean the Slicer” on page 6.
3. Remove the sharpener.
4. Rotate the blade so that the screw holes are parallel to the base of the slicer.
5. Place the safe blade removal tool on the blade and align the two knobs on the tool with the holes in the blade.

Tip: Rotate the tool so the warning label is at the top of the tool and the notch fits around the bump out of the blade guard.



6. Tighten the knobs to secure the tool to the blade.
7. Remove the screws that fasten the blade to the slicer.
8. Lift the safe blade removal tool to remove the blade.
9. Reverse the procedure to reinstall the blade.

MAINTENANCE

Daily

- Inspect the slicer before each use.
- Clean and sanitize the slicer.

Weekly

- Sharpen the blade weekly or any time that cutting becomes difficult and/or produces a large amount of waste. The slicer should be considered and treated as a knife: If it is not adequately sharpened, the slicing results will be poor and the slicer will be overloaded.

Monthly

- Lubricate the carriage slide guides

Sharpen the Blade



WARNING

Cut and Amputation Hazard

The blade on this commercial slicer is extremely sharp. Severe injury can occur if care is not used when using or cleaning this product. Only trained personal should operate equipment or perform maintenance. To reduce the risk of injury, the use of a cut resistant glove(s) is recommended when cleaning this equipment.

1. Turn the index control to the zero (0) position.
2. Press and release the OFF (O) button.
3. Unplug the slicer from the electrical outlet.
4. Clean the blade to remove any grease or food.

5. Lift the sharpener and rotate it 180° counter clockwise.

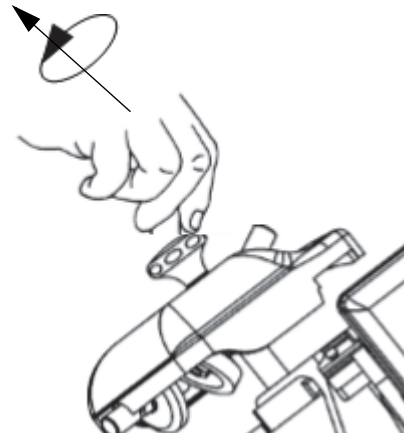

6. Position the sharpener so the blade is between the sharpening stones.

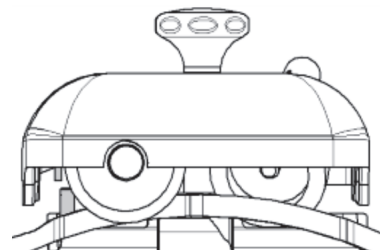

7. Plug the slicer into the electrical outlet.
8. Press and release the ON (—) button.

9. Press and hold the burring stone button. Let the blade rotate against the deburring stone for 30-40 seconds. Release the button.

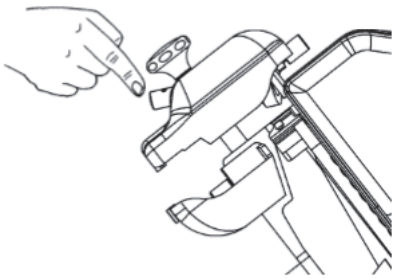

10. Simultaneously press and hold the sharpening stone buttons for 3-4 seconds. Release the buttons.

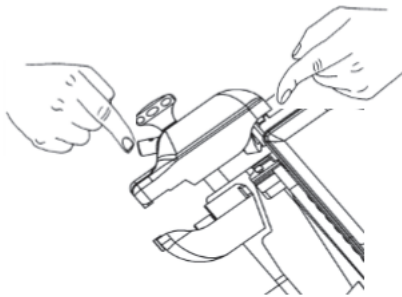

NOTICE: Pressing the buttons for longer than 3-4 seconds could bend the blade, which could then damage the slicer.

11. Press and release the OFF (O) button and unplug the slicer.
12. Return the sharpener to the original position.
13. Clean the slicer. See “Clean and Sanitize the Slicer” on page 5.

Lubricate Carriage Slide Guides

Lubricate the carriage slide guides at least once a month and any time that pushing the tray becomes difficult. Use the oil supplied with the slicer or a food safe lubricant. Do NOT use cooking oil.

1. Press and release the OFF (O) button.
2. Unplug the slicer from the electrical outlet.
3. Put a few drops of the oil that was supplied with slicer into the carriage slide lubricant access hole (OIL) on the front of the slicer.

SERVICE AND REPAIR

Serviceable parts are available on Vollrath.com.

To avoid serious injury or damage, never attempt to repair the unit or replace a damaged power cord yourself. Do not send units directly to The Vollrath Company LLC. Please contact Vollrath Technical Services for instructions.

When contacting Vollrath Technical Services, please be ready with the item number, model number (if applicable), serial number, and proof of purchase showing the date the unit was purchased.

WARRANTY STATEMENT FOR THE VOLLRATH CO. L.L.C.

This warranty does not apply to products purchased for personal, family or household use, and The Vollrath Company LLC does not offer a written warranty to purchasers for such uses.

The Vollrath Company LLC warrants the products it manufactures or distributes against defects in materials and workmanship as specifically described in our full warranty statement. In all cases, the warranty runs from the date of the end user's original purchase date found on the receipt. Any damages from improper use, abuse, modification or damage resulting from improper packaging during return shipment for warranty repair will not be covered under warranty.

For complete warranty information, product registration and new product announcement, visit www.vollrath.com.



Outperform every day.™

www.vollrath.com

The Vollrath Company, L.L.C.

1236 North 18th Street
Sheboygan, WI 53081-3201 U.S.A.
Main Tel: 800.624.2051 or 920.457.4851
Main Fax: 800.752.5620 or 920.459.6573
Customer Service: 800.628.0830
Canada Customer Service: 800.695.8560

Technical Services

techservicereps@vollrathco.com
Induction Products: 800.825.6036
Countertop Warming Products: 800.354.1970
All Other Products: 800.628.0832