

EGN Series Electric Countertop Griddles

EQUIPMENT
AVANTCO

Durable stainless steel construction with adjustable legs, a powerful heating element, and a compact footprint make Avantco countertop griddles a perfect addition to your concession stand, snack bar, or sandwich shop.

- Heavy duty stainless steel construction
- Stainless steel legs adjust from 3½"-5½"
- 120°-570° F temperature control
- 3" Steel side and back splashguards
- Removable grease pan
- CE and ETL Sanitation Listed
- Perfect for quickly preparing breakfast foods, chicken, beef, fish and grilled vegetable dishes.



**EG16N - 16" Electric
Countertop Griddle**

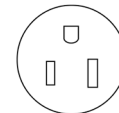

NEMA 5-15P

Description

Expertly cook pancakes, burgers, eggs, grilled cheese, and all of your customers' favorites with this Avantco EG16N 16" electric countertop griddle. The 1/2" thick steel cooking surface heats evenly throughout for consistent cooking results no matter where you place food on the griddle plate. A single thermostat knob controls the temperature, which is adjustable from 120-570 degrees Fahrenheit. With overheat protection, power on / heating indicator lights, and 3" steel splashguards on the sides and back, the Avantco electric countertop griddle is as safe to use as it is powerful and effective.

Thanks to its 15 1/2" x 16" griddle plate, this unit is built for high-volume commercial use. The heavy duty stainless steel housing and 3 1/2" to 5 1/2" adjustable stainless steel feet provide durability, while the easy to remove grease tray allows for quick, hassle-free cleaning.

This Avantco electric griddle requires a 120V electrical connection for operation and comes with a one year replacement warranty. CE and ETL Sanitation Listed. NEMA 5-15P plug included.

This model replaces the Avantco EG16 electric countertop griddle.

Features

- Heavy duty stainless steel construction
- 15 1/2" x 16" cooking area
- Stainless steel adjustable legs (3 1/2" to 5 1/2")
- Temperature control knob
- 3" side and back splashguards
- 120V, 1750W
- CE and ETL Sanitation Listed
- Backed by a one year warranty

Technical Data

Dimensions	16 1/2"W x 19 3/4"D x 9 1/2"H
Temperature Range	120° - 570° F
Wattage	1750W
Voltage	120V
Cord Length	6'

Plan View

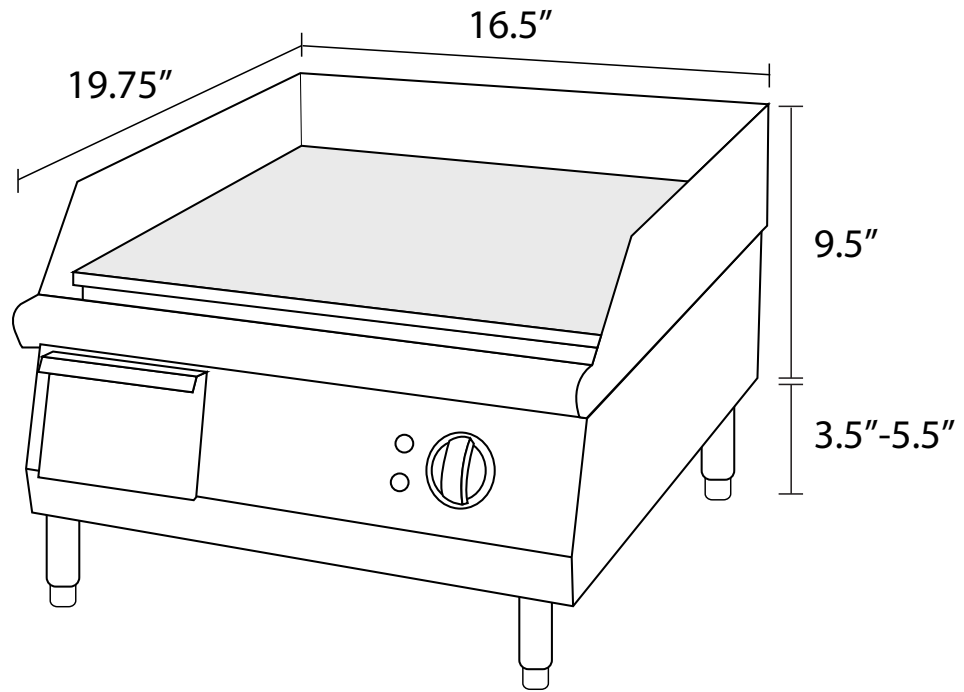

Recommended Companion Product

FORMULA-D

Attack tough grease, oil, and carbon with this ready to use decarbonizer and degreaser. Its unique formula is designed to clean ovens, grills, hoods and a wide variety of other surfaces. (#147FORMULAD)