



Price computing scale

PC SERIES



Model:

PC40L-HS

PC80L-HS

Product features

- Available in 40 lb and 80 lb capacity
- LCD Display with backlight
- 100 hour rechargeable battery
- Progressive Tare Function
- NTEP Legal for commercial trade
- Stainless Steel case and plate
- Cash register functions
- 4 direct access keys and up to 100 PLU's
- AC charger (Included)
- Accuracy Class III

Product highlights



Robust stainless steel construction

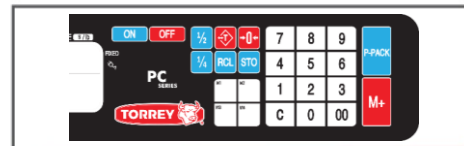

New easy-touch keyboard



High resistant stainless steel plate

Certifications



Warranty





Price computing scale

PC SERIES

Dimensions

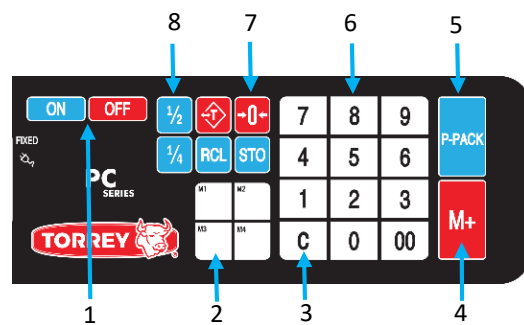
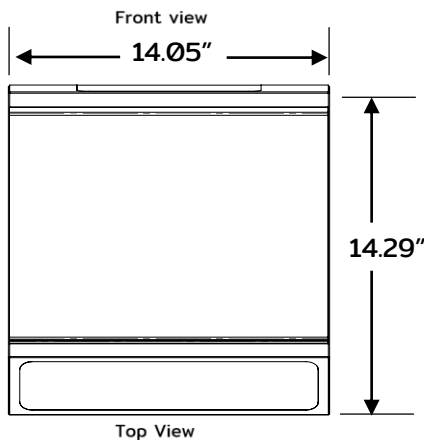
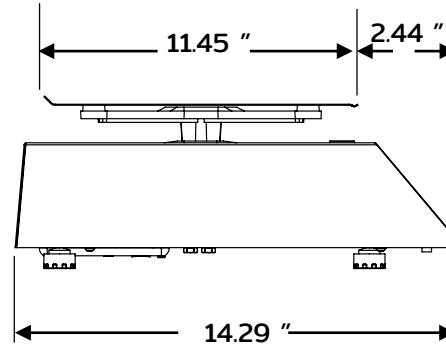
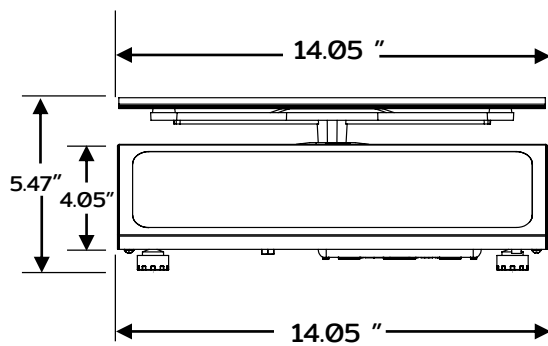

Keypad Overview

- 1- ON/OFF
- 2- MEMORY ACCESS
- 3- CANCEL
- 4- ADD PRODUCT
- 5- PRE-PACK MODE
- 6- NUMERICAL KEYPAD
- 7- ZERO AND TARE BUTTONS
- 8- SET PRICE FOR 1/2 OR 1/4

Technical specifications

Dimensions

External dimensions	W: 14.29" D: 14.05" H: 5.47"
Packaging dimensions	W: 17.32" D: 18.50" H: 6.88"
Gross weight	17 lb.
Shipping Weight	19.62 lb.
Plate dimensions	W: 11.45" D: 14.05" H: 1.00"

Construction

Scale Construction	Stainless steel
Platform Construction	Stainless steel
Plate holder material	Aluminum
Leveling feet	4

Logistic data

Units per pallet	44
Weight per pallet	903.89 lb.
Dim. per pallet	44.88" X 51.96" X 78.74"

Electrical data

Power supply	110/220VAC - 6VDC 500mA
Battery	Rechargeable Battery 4VDC 2.5A/h
Battery Life	100 Hours (no backlight) Aprox 6 Hours (Suspend mode)
Charging time	12 Hours
Display	LCD with Backlight

Performance data

Capacity	40 lb / 80 lb
Minimal division	0.01 lb / 0.02 lb
Maximum tare	40 lb / 80 lb
Operation temperature	14°F to 104°F (-10°C to 40°C)
Storage temperature	-4°F to 122°F (-20°C to 50°C)

Additional data

Connectivity	RS232 Serial
Maximum price	\$999.99
Maximum total	\$9999.99
Memory	100 PLU
Accuracy Class	III
Warranty	1 year