



Project \_\_\_\_\_  
 Item \_\_\_\_\_  
 Quantity \_\_\_\_\_  
 CSI Section 11400 \_\_\_\_\_  
 Approval \_\_\_\_\_  
 Date \_\_\_\_\_

NOBLE UL30

## NOBLE UL30



### Standard Features

- Automatic fill
- Push button start
- Labyrinth type door design
- Automatic pumped drain for floor and wall drain installations
- Recirculating wash and rinse
- Stainless steel wash/rinse pump
- Universal Timer
- Manual override for extended wash and delimiting
- Simplified controls allow easy access for operation and service
- Door switch
- Low product indicator light
- One (1) each peg and combination rack included
- Above water scrap basket
- Built-in chemical pumps and priming switches

### Options

- Scale Prevention System (SPS)
- Replacement cartridge for SPS
- Water Hammer Arrestor
- Back Panel
- Tie Down

### Accessories

- 36-Compartment Rack
  - 4-1/8" tall (105 mm)
  - 5-5/8" tall (143 mm)
  - 7" tall (178 mm)
- Combination Rack
- Peg Rack
- Machine Stand
  - 6" (152 mm) high
  - 18" (457 mm) high

## Specifications

- Uses 1.2 gallons (4.5 liters) of water per rack
- Uses 28.8 gallons (109 liters) of water per hour
- Cleans 24 racks per hour
- Two minute automatic cycle
- Powerful 1 hp wash pump motor
- Air insulated between body and stainless steel housing
- Durable stainless steel construction
- Low product indicator light alerts operator when detergent and sanitizer are low

### Notes:

A vent hood is not recommended above the NOBLE UL30 as it does not produce excessive vapors. Always check with the local building code to know what type of ventilation is required for commercial dish machine installations in your area.

Normal operation of the NOBLE UL30 generates steam that may escape from the door. Materials such as wood laminate, veneers, etc. are unsuitable for use in areas exposed to dishwasher steam and detergents. Stainless steel or other moisture-resistant shields are recommended for surfaces adjacent to NOBLE UL30 sides and top.



Intertek



**LEGEND:**

- A - Water Inlet - 1/2" Female Pipe Thread, 2 1/2" AFF (Connect to a true 1/2" ID water line)
- B - Electrical Connection
- C - Drain Connection - 6' coiled drain hose. Shipped inside machine. Must be installed no more than 24" AFF.

All dimensions from floor can be increased 1" with adjustable feet supplied.

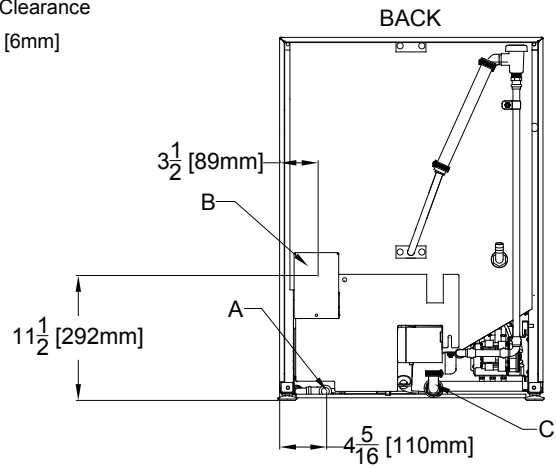
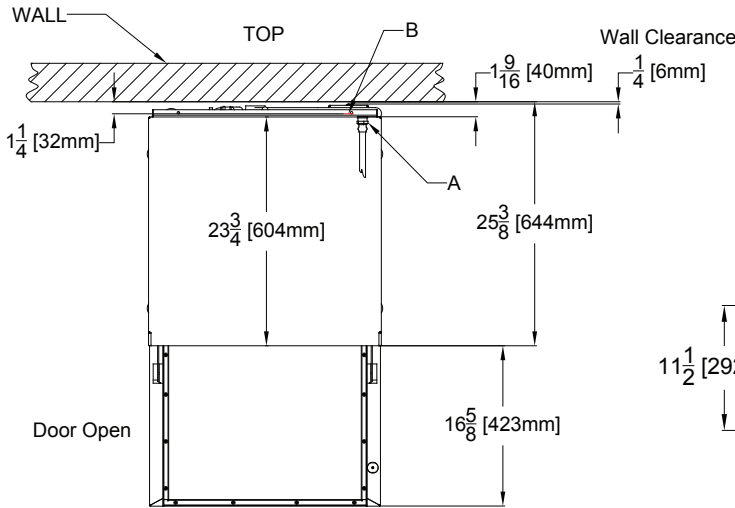
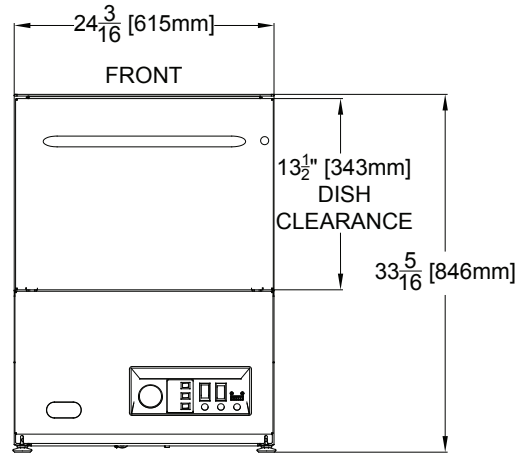

| MODEL NO.  | MACHINE DIMENSIONS      |                        |                        |                 | WALL CLEARANCE | SHIPPING INFORMATION |       |              |               |              |              |
|------------|-------------------------|------------------------|------------------------|-----------------|----------------|----------------------|-------|--------------|---------------|--------------|--------------|
|            | INSIDE CLEARANCE HEIGHT | INSIDE CLEARANCE WIDTH | INSIDE CLEARANCE DEPTH | DOOR OPEN DEPTH |                | WEIGHT               | CLASS | CUBE         | HEIGHT        | WIDTH        | DEPTH        |
| NOBLE UL30 | 13-1/2" (343 mm)        | 20" (508 mm)           | 20" (508 mm)           | 42" (1067 mm)   | 1/4" (6 mm)    | 248 lbs (112 kg)     | 92.5  | 23.3 cu. ft. | 42" (1067 mm) | 33" (838 mm) | 29" (737 mm) |

| APPROXIMATE TOTAL AMP LOADS |      |
|-----------------------------|------|
| 115/60/1                    | 13.2 |

| OPERATING CAPACITY |     |
|--------------------|-----|
| Racks per Hour     | 24  |
| Dishes per Hour    | 600 |
| Glasses per Hour   | 864 |

| WASH PUMP MOTOR |      |
|-----------------|------|
| Wash Pump       | 1 hp |

| OPERATING CYCLE       |     |
|-----------------------|-----|
| Wash Cycle (seconds)  | 56  |
| Drain Time (seconds)  | 29  |
| Rinse Cycle (seconds) | 35  |
| Total Cycle (seconds) | 120 |

| WATER REQUIREMENTS   |                  |
|----------------------|------------------|
| Gallons per Rack     | 1.2 gal (4.5 L)  |
| Gallons per Hour     | 28.8 gal (109 L) |
| Flow Pressure (PSI)  | 15 - 25          |
| Waterline Size (IPS) | 1/2"             |
| Drainline Size (OD)  | 1-3/8"           |

| OPERATING TEMPERATURES |                |
|------------------------|----------------|
| Wash                   | 140° F (60° C) |
| Rinse                  | 140° F (60° C) |

**HOW TO SPECIFY:** NOBLE UL30